

# **FOXTROT – Control Your House!**

## **CFox, RFox - Design and installation guide**

Revision 1k

August 2011



**Teco a.s. Havlíčkova 260, 280 58 Kolín, [www.tecomat.com](http://www.tecomat.com), [www.controlyourhouse.com](http://www.controlyourhouse.com)**

**Content:**

List of document updates.....	3
1 System overview, basic components.....	4
2 Basic module, Power supply.....	5
2.1 Power supply.....	5
2.2 Basic module CP-1000, CP-1020.....	6
2.2.1 CP-1000, power without backup.....	6
2.2.2 CP-1020, power with backup.....	8
3 CIB bus, RFox network, TCL2 bus.....	9
3.1 CIB – the principles of design and installation.....	9
3.1.1 CIB characteristics.....	9
3.1.2 Powering CIB buses – limitations, optimisations.....	12
3.1.3 CIB master CF-1141.....	13
3.1.4 Coupling of CIB to the power supply – C-BS-0001M coupler.....	15
3.1.5 Surge protection of CIB – DTNVEM 1/CIB and DTNVE 1/CIB.....	16
3.2 RFox network – principles of design and installation.....	18
3.2.1 RFox basic characteristics.....	18
3.2.2 System function configurations, properties.....	18
3.2.3 RFox master RF-1131.....	20
3.2.4 RFox router R-RT-2305W.....	21
3.3 TCL2 system bus – principles of design and installation.....	22
4 Heating.....	22
4.1 Hot water heaters – actuator control.....	22
4.1.1 Motorized drive C-HC-0201F-E.....	24
4.1.2 Two-position drive Alpha AA controlled by relay output.....	25
4.1.3 Proportional drive Alpha AA 5004 controlled by 0÷10V signal.....	26
4.2 Underfloor hot water heating.....	27
4.3 Underfloor electrical heating.....	28
4.4 Floor convectors – proportional control.....	29
4.4.1 Floor convectors wit 24VDC EC motors (by ISAN).....	29
4.4.2 Floor convector MINIB – connection to the Foxtrot system.....	30
4.5 FanCoils - control.....	31
4.5.1 AERMEC FCXI – connection example.....	32
4.6 Boiler - Control and regulation of heating sources.....	33
5 Ventilation.....	34
5.1 Fan speed control, heat recovery units.....	35
5.2 inVENTer - decentralized ventilation unit with heat recovery .....	36
6 Lighting.....	37
6.1 Switching LED lights.....	38
6.1.1 Switching of external voltage or current switching power supply for LED power supply.....	38
6.2 Switching incandescent bulbs - 230 VAC or 12 VDC .....	40
6.3 Dimming of LED stripes, controlled by 12V or 24V voltage.....	41
6.4 Dimming of power LED, current supply for 350 mA, 500 mA, 700 mA, 1000 mA.....	42
6.5 Dimming – DALI interface.....	43
6.6 Dimming of fluorescent lights and compact fluorescent lamps .....	44
6.7 Dimming – Low voltage lights with inductive and electronic transformers.....	45
6.8 Dimming – incandescent lamps.....	46
6.9 Dimming – DMX512 control.....	47
7 Shutters, blinds.....	48
7.1 Controlling engines for outdoor shutters, awnings, etc. ....	48
7.2 Control of DC motors for shutters and blinds.....	50
8 Security Systems, Fire Alarm System.....	51
8.1 Security sensors (PIR, ... ).....	51
8.1.1 Configuration of inputs for Security sensors.....	51
8.1.2 Connecting securitz sensor with double balanced loop.....	52
Fire alarm systems – wiring of detectors.....	52
9 Communication with the user.....	53

9.1 Wall switches flush mounted (Light control, shutters, etc.).....	53
9.1.1 System wall switches on CIB	
To control lighting, blinds, ventilation and similar applications you can use the driver C-WS-0200R with one gang and 2 buttons – one on top one on bottom and/or C-WS-0400R with two gangs and 4 buttons. Both types of drivers are made in the design of ABB Time and enable to attach up to two temperature sensors: .....	53
Indoor temperature with 12k NTC sensor available also in ABB's Time design.....	53
Floor temperature with sensor fixed on the cable.....	53
9.1.2 Wall switches coupled to CIB over input module.....	54
9.1.3 Push buttons coupled over the module in cabinet.....	55
9.2 Displays and Heating control on the wall.....	56
9.2.1 Heating control module C-RC-0002R-design.....	56
9.2.2 Heating, air conditioning, light control module RCM2-1.....	57
9.3 Infrared control.....	58
9.3.1 IR transmitter and receiver C-RI-0401R-Time with the design on the wall.....	59
10 Temperature sensing.....	60
10.1 Room temperature measuring.....	61
10.1.1 Temperature sensor as CFox module in the wall design.....	61
10.1.2 Temperature sensor as CFox module in the ABB wall design.....	62
10.2 Temperature measuring – with IP 65 housing.....	63
11 Metering of energy and non-electric values.....	64
11.1 Measurement of electric energy.....	64
11.2 Connecting the electricity meter by optical probe according to standard EN 62056-21.....	65
11.3 Heat and flow measurement.....	66
11.4 Air quality measurement.....	67
11.5 Mains parameters measurement.....	67
11.6 Meteostation.....	69
11.7 M-bus meters integration, SX-1181 module.....	70
11.8 M-bus meters integration – MR-0158 submodule.....	72
11.9 Measuring and monitoring of water level.....	74
11.9.1 Continuous measurement of water level in the well or tank.....	74
11.9.2 Limit monitoring water level in the well or tank.....	75
12 Control and monitoring of other technologies.....	76
12.1 Defrosting of outdoor areas.....	76
12.2 Defrosting the gutters.....	78
12.3 Pool technology control, integration.....	79
12.3.1 pH and Redox (chlorine) measuring.....	79
13 Design and installation information.....	80
13.1 Consumption of CFox modules from CIB or from external power supply.....	81
13.2 Module dimensions.....	82
13.2.1 9M housing for DIN rail TS 35, according to EN 60715.....	82
13.2.2 6M housing for DIN rail TS 35, according to EN 60715.....	82
14 Basic application examples of CFox a Rfox modules.....	83
14.1 C-OR-0008M, relay outputs, CFox.....	84
14.2 C-HM-0308M.....	85
14.3 C-HM-1113M.....	86
14.4 C-HM-1121M.....	87
14.5 C-IT-0200S.....	88
14.6 C-IR-0202S.....	89
14.7 C-IT-0504S.....	90
14.8 C-IT-0200R-Design.....	91
14.9 C-DL-0012S.....	92
14.10 C-RC-0002R.....	93
14.11 C-RI-0401R-Design, C-RI-0401R.....	94
14.12 C-IT-0200I.....	96
14.13 RCM2-1.....	99
15 Literature.....	100

## List of Revisions

### Rev.1k:

- Mistake in Fig 11.8.1 fixed (Wrong terminal numbers)
- Information about the Alpha AA thermostatic valves was added to chapter 4.1.2 a 4.1.3.
- Chapter added: 4.5.1 - Example of control of Fancoil FCXI.
- Chapter added: 11.9 - continuous and limit measurement of level in the tank.
- Chapter added: 13.1 -table of CIB modules consumption
- Chapter added: 9.3.1 - IR transmitter and receiver C-RI-0401

# 1 System overview, basic components

Foxtrot control system can connect its peripherals by

- CFox modules on CIB - Common Installation Bus,
- RFox modules – Wireless
- TCL2 bus for high speed PLC modules

## **Foxtrot basic modules CP-10xx are the central points of the system**

The CP-1000 basic module is the right choice for installations where we do not assume to connect sensors and actors directly to the basic module. Also for installations parametrized in the FoxTool.

The other Foxtrot basic modules (See [Foxtrot design and installation guide TXV 004 11](#)) are suitable for installations where all or majority of inputs and outputs should be connected directly to the basic module.

Sensors like temperature sensors, push-buttons etc and actors like lights, valve, shutters and fan drives are to be connected to the expansion modules via one of 3 buses above.

### **CIB - Common Installation Bus (CFox modules):**

The major amount of peripherals in building automation are connected to CIB. The peripheral modules are supplied with CFox brand. They are available in different housings especially for DIN rail mounting in centralized cabinets, for flush box installation, in interior design for the wall mounting and also in the IP65 housing. A detailed description of the CIB is shown in the following chapters.

### **RFox wireless network (bus):**

Other possibility to install modules of Foxtrot system is wireless network RFox. It is not real bus, but the modules are controlled by the same way as CFox modules on CIB. RFox modules are also available in different housings – for DIN rail powered by 230VAC or 24VDC, for flush box – powered by battery or 230VAC, in interior housing and in IP65 housing. Detailed descriptions of RFox modules are shown in following chapters.

### **TCL2 bus:**

It is the system bus of PLC. There is not so wide range of types of peripheral modules. The bus has to be wired strictly as linear line and it has other strict requirements for installation. Detailed description of the TCL2 bus is in the [TXV 004 11 manual](#). Peripheral modules on the TCL2 bus are available only for DIN rail installation. In building control installations, this bus is often used to connect external master modules CFox (CF-1141) and RFox (RF-1131) or some communication modules like Open Therm and MP-Bus.

Input and output modules connected via any bus above are equal from the point of programming, parametrization and configuration. Only RFox modules powered from batteries has slight differences like longer period of refresh of the new value, measuring the battery status ...

To switch the light it is not important if the light is connected to the relay output of CFox, RFox, TCL2 module or directly to the relay on the basic module.

Apart the initial configuration the programmer need not take care about which relay is used

## 2 Power supply, Foxtrot basic modules,

### 2.1 Power supply

System Foxtrot and the CFox modules on CIB - Common Installation Bus are supplied by the 24VDC or by 27,2 VDC in case of battery backup of all the installation. The accepted tolerance of the power supply output is in [chapter 3.1.1 with the CIB description](#).

#### **Power supply parameters:**

It is highly recommended to use the power supplies specified in this documentation even if you can use also other types with adequate parameters. Majority of power supplies with the stabilized output voltage 27.2 VDC or 24 VDC are suitable. The power supply must comply the SELV standard, 27.2V supply must be specifically designed for direct battery charging. Also power supply with stabilized 24 VDC output voltage (for system without backup) can be used. Extra care must be taken over the output voltage since some power supply with extra power can supply the higher output voltage than it is allowed.

#### **Power determination of the power supply:**

To power the CP-1000 itself (without modules on CIB) can be used the power supply min. 15W like recommended type DR-15-24. If you supply also other modules from the same power supply, you have to increase the power accordingly. To supply the basic module and both internal buses CIB (see also [chap.2.2.1. Supply without backup](#)) DR-60-24 or DR-100-24 is recommended. To supply the system with battery backup the PS2-60/27 is recommended (see . [chap.2.2.2. Supply with backup](#)).

#### **Fuse Protection:**

Input power (27V + terminal) is protected by internal electronic fuse. We recommend install external fuse with nominal value of T3 15L250V for the central module CP-10x0 fully equipped with both CIB branches.

#### **SELV:**

If the power supply meets the parameters of the source SELV according to EN 60 950 (ČSN 33 2000-4-41), then all I/O circuits meet SELV accordingly. Even if the relay outputs switch low voltage circuits it meets the requirement since isolation between relay output and the internal circuits of the system is 4kV AC). Power supplies for system Foxtrot recommended above meet parameters of SELV.

#### **Improvement the reliability of power supplies:**

To ensure trouble-free operation even in exceptional situations (lightning effects, poor quality of power grid or influence of other devices with the recourse to the grid it is recommended for the power supply 230VAC to install suitable surge protection equipment.

## 2.2 Foxtrot Basic modules

The following chapters describe the basic modules CP-1000 and CP-1020. The other Foxtrot basic modules (eg, CP-1006, etc.), including the principles of usage and their installation are described in the [Foxtrot design and installation guide, TXV 004 11](#).

### 2.2.1 CP-1000, example of powering without backup

CP-1000 is the simplest variant of the basic module for home and building installation.

The basic module is powered from 24 VDC power supply. Both branches of CIB on connector B are powered directly over the basic module. No other module is necessary to power the CIB buses. All coupling components are integrated directly in the basic module CP-1000.

The system bus TCL2 is available on connector A, especially for external masters CF-1141 and RF-1131. Serial communication channel CH1 is usually used for a GSM modem.

On the connector D the slot for other communication interface is placed. The optional sub-modules inserted to this slot enable to implement interfaces such as RS485, M-Bus Master, CAN, RS232 and more. Possible variants of interface sub-modules are described in [Foxtrot design and installation guide, TXV 004 11](#)

The E and F connectors enables connecting auxiliary inputs and outputs: 4 universal AI/DI (for contacts, NTC, Pt1000, Ni 1000), 2 independent relay outputs 3A, input for HDO (as signal of low tariffication of electricity distributor) and input IN 230 VAC (as standard binary input 230 VAC).

#### **Backing up the internal data and time of CP-1000 during the power failure:**

When power of CP-1000 falls down, the selected user data and calendar and clock are backed up. Back up is provided by internal Li-Ion battery. After power is restored the battery recharges and is ready to back up again. The battery requires no maintenance. Li-Ion battery backup will last approximately 500 hours.

#### **Additional internal backup battery**

If the backup time has to be increased (eg. to switch-off the power supply for more than 500 hours), the additional lithium battery of CR2032 type can be inserted into the ready to insert holder. After discharge of the Li-Ion battery this CR2032 will provide power and extend the backup time up to 20,000 hours.

Preventive replacing of the backup battery type CR2032 or equivalent, (3 V, diameter 20 mm, thickness 3.2 mm), it is recommended at intervals of 2-3 years. Battery life is typically 5 years. The battery has to be inserted in the holder located on the inner board and the basic module and is accessible after removing the plates from the plastic cover (more information is available in basic documentation of each module).

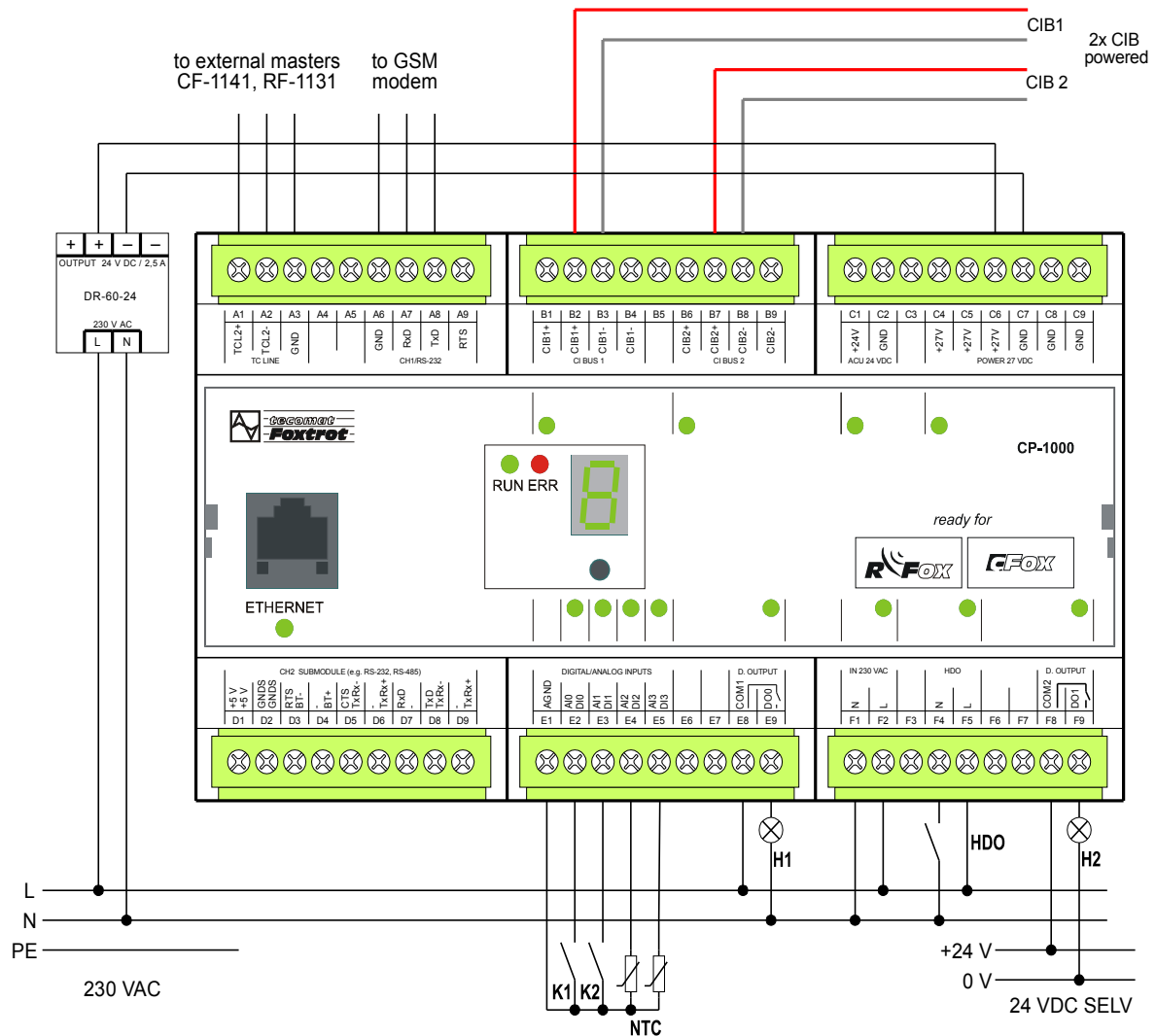

Fig. 2.2.1.1. Example of the power supply of CP-1000 without a backup

Notes:

- 1) We recommend a DR-60-24 - stabilized power supply of 24 VDC, complying SELV. Power consumption of CP-1000 is the sum of its own power (typically 3W) and the total wattage of all connected modules CFox on both of CIB branches.
- 2) On terminal B there is the output of both powered CIB branches for a maximum current of 1 A for each branch.
- 3) Inputs to AI/DI0 up-to AI/DI3 are 4 universal inputs (for dry contacts or temperature sensor NTC, Pt1000, Ni1000).
- 4) IN 230 VAC input (terminals F1 and F2) is designed for monitoring the presence of 230V mains directly on the grid. It is a standard 230VAC input, galvanic isolated.
- 5) HDO input (terminals F4 and F5) is for connection of the tariffication signal coming from the grid. This input is tolerant to many failures of the power grid even to installation mistakes.
- 6) DO0 and DO1 outputs are standard electromechanical relay 3A the contact electrically isolated from other circuits.



### 2.2.2 CP-1020, example of backup powering

The CP-1020 basic module on the contrary to CP-1000 is equipped with an internal master of RFox network. Together with 2 x32 peripheral modules on the two branches CIB bus you can directly connect up the 64 RFox peripheral elements on the basic module. Antenna output is on the front panel as SMA connector.

The antenna has to be placed according to the best RF coverage of the desired amount and placement of all RFox modules. You can use either a short antenna fitted directly to the SMA connector, or a vertical whip antenna connected over the 2 m cable with SMA connector. More information about RFox network elements are presented in [chapter 3.2](#). Other features are consistent with the basic module CP-1000, see the previous chapter.

Using Foxtrot also for security purposes, it is essential to back up all the system by batteries. The power supply must be capable of providing power from battery for the required period and vice versa it must ensure the continuous charging of the backup battery. For this purposes the PS2-60/27 power supply with output voltage 27.2V DC is recommended. It can supply the system and charge the batteries.

PS2-60/70 has also output of 12 VDC, max 300 mA for security sensors. This power supply is active even when running applications from connected batteries. For backup, it is necessary to use two encapsulated lead-acid batteries 12V DC (typically with a capacity of 7 Ah to 28 Ah) connected in series - see following figure.

The presence of AC voltage 230 VAC in the mains can be detected at input IN 230VAC (mains voltage connected to terminals F1 and F2). The basic module measures the value of the main supply voltage (ie voltage at terminal C). The state of the input IN 230VAC and voltages can be evaluated as the presence of mains voltage 230VAC so running from the battery and measuring the voltage we can indicate a time upcoming discharge (by SMS, etc.).

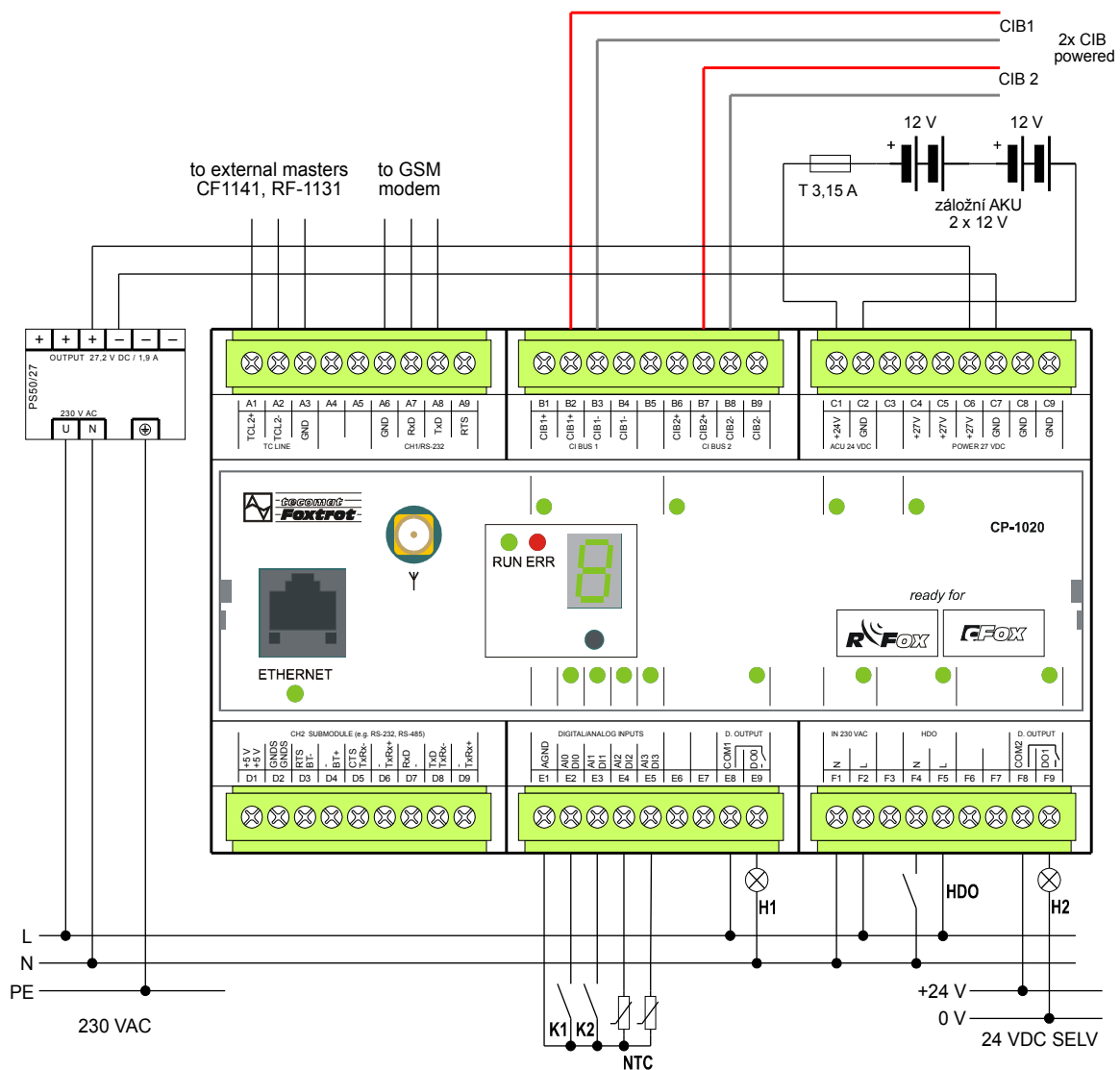

Fig. 2.2.2.2. Example of the power supply of CP-1020 with a backup

Notes:

- 1) We recommend PS2-60/27 - stabilized power supply of 27,2 VDC, complying SELV. Power consumption of CP-1020 is the sum of its own power (typically 4W) and the total wattage of all connected modules CFox on both of CIB branches.
- 2) On terminal B there is the output of both powered CIB branches for a maximum current of 1 A for each branch.
- 3) Inputs AI/DI0 up to AI/DI3 are 4 universal inputs (for dry contacts or temperature sensor NTC, Pt1000, Ni1000)
- 4) IN 230 VAC input (terminals F1 and F2) is designed for monitoring the presence of 230V mains directly on the grid. It is a standard 230VAC input, with galvanic isolation.
- 5) HDO input (terminals F4 and F5) is for connection of the tariffication signal coming from the grid. This input is tolerant to many failures of the power grid even to installation mistakes.
- 6) DO0 and DO1 outputs are standard electromechanical relay 3A the contact electrically isolated from other circuits.

## 3 CIB bus, RFox network, TCL2 bus

### 3.1 CIB – the principles of design and installation

CIB bus enables to connect CFox peripheral modules to the Foxtrot basic module. CFox modules are intended for building and home automation, for HVAC etc. but they can be used in any application as a standard I/O respecting their characteristics.

CIB bus is master/slave. One CIB master enables to connect max. 32 slave modules. CP-1000 and CP-1020 has 2 embedded and powered CIB masters. Other basic modules CP-10x4, CP-10x5, CP-10x6 and CP-10x8 have only one CIB master. More CIB slaves can be connected via external CIB masters CF-1141. Each CF-1141 contains 2 powered CIB masters for 2x 32 CIB slave modules. Max. 4 CF-1141 modules so totally 8 CIB masters can be connected to one Foxtrot basic module. CF-1141 modules have to be connected via TCL2 system bus [See chap. 3.3](#)

#### 3.1.1 CIB characteristics

CIB – Common Installation Bus is 2 wire bus with arbitrary topology. The communication is modulated and superimposed on the DC supply voltage. CIB bus can be powered by the standard power supply 27,2VDC or 24VDC coupled by the couplers embedded in basic modules CP-1000/1020, in CF-1141 or by standing alone coupler C-BS-0001M. Such power supply can supply the basic module at the same time.

Besides the communication over 2 wires, CIB bus enables to power all connected modules. The care must be taken only about the max. voltage drop along the wires so the voltage on the most remote module should be within recommended tolerances

Rated voltage of the CIB bus (with backup)	27,2 VDC	+ 10%, - 25%
Rated voltage of the CIB bus (without backup)	24 VDC	+ 25%, - 15%
Topology	Arbitrary	
Max. distance between master and most remote slave <sup>1)</sup>	about 500 m	

<sup>1)</sup> Max. length of one branch is mostly limited by the voltage drop along the cable. Also at the most remote module there must be voltage within the tolerances seen above

For the CIB wiring can be used any 2 wire (or more) cables. However it is recommended as a good practice to use the shielded twisted pairs with the wire diameter 0,6mm at least, the optimum is 0,8 mm (with the resistance of the wire approx. 7 Ω / 100 m), e.g. J-Y(St)Y1x2x0,8, or YCYM 2x2x0,8. The cross-section and topology has to be designed primarily with respect to voltage drops in cables according to amount of CFox modules.

#### Basic rules for CIB installation

- CIB bus enables arbitrary topology – line, star, tree. Only avoid to enclose the circle!
- It is recommended to minimize the parallel layout of CIB and power cables (with 230VAC) as a good practice. It depends on the real possibilities at the site. But no special requirements and limitation for it is not set.
- For larger installations the voltage drops along the whole installation has to be checked to eliminate the voltage below the tolerance at each CIB module.
- The galvanic isolation of inputs and outputs in each module should be taken into account during the installation. Only modules declared for 230VAC usage have safe galvanic isolation always.
- CIB installation has to be designed always with respect to SELV or PELV safety requirements

#### Basic rules for shielded cable usage:

- The shield of the internal and external wires in the cabinet has to be connected only at one side and to the main protective earth PE of the cabinet – together with the earth rack of the cabinet.
- At the metallic cabinet the shield of the external cables are to be connected at the entry into the cabinet directly to the metallic case.

- At the plastic cabinet the shield of the external cables are to be connected as close as possible at the entry into the cabinet directly to the base metallic mounting plate.
- The shield is connected by cross section as large as possible directly to the grounded areas of cabinet (base plate etc.). In case of using terminals, the unraveled and then twisted shield should be used.
- The shield cannot be connected using extension wires.

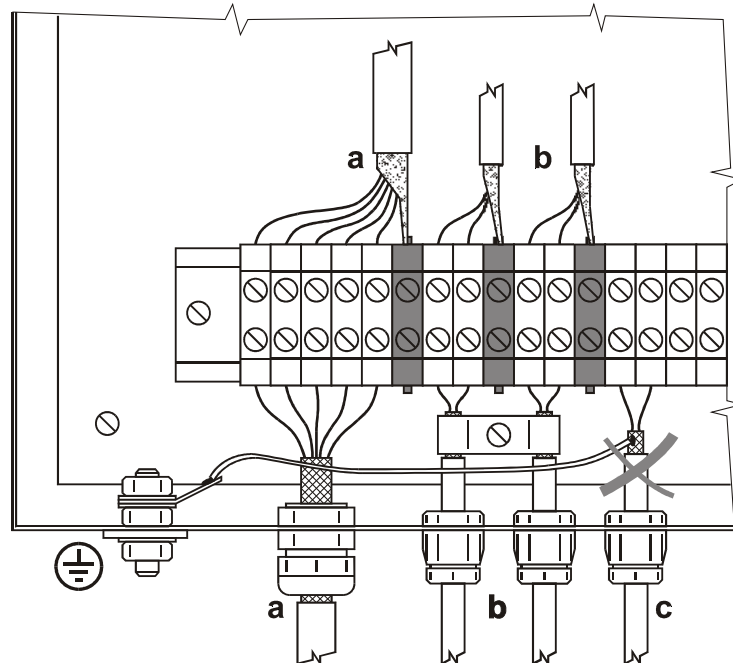

Fig. 3.1.1.1 Example of the shield wiring in the cabinet

Variants:

- The shield of the incoming cable is connected with the ground using the special metallic cable entry ready to made for shielding with the outer case of cabinet (like Progress MS EMV by IES see the picture). This way is the most efficient since it minimizes the emitting interferences into the cabinet. The earthing of the shield is provided by the earth terminal, base plate and protection terminal.



- The shielding of the external cables is connected with the ground by the metal clips, mounting plates and protective clamps. Shield of the inner cable is connected to the ground via grounding clamps, mounting boards and protective clamps. This or another similar method is particularly suitable for plastic panels with a metal mounting plate.
- The inappropriate way to connect the shield is shown as **c** on the picture. Cable shielding is indeed associated with protective terminal, but the connection wire degrades shielding effectiveness and long loop is being introduced so the radiation of electromagnetic interference is introduced into the cabinet.

### 3.1.2 CIB powering – limitations, optimizations

#### **Amount of modules on the CIB branch.**

Max. number of CFox modules connected to one branch/one master is 32. This number cannot be exceeded.

On the contrary the number of modules in the CIB branch must be reduced in case of using more modules with the higher consumption from CIB like C-HM-1113M. It is in order to avoid the exceeding of the maximum current supplied from the master and coupled from power supply. See the relevant documents of CIB master or CIB coupling module.

It is always useful to calculate the total consumption of modules to be ensured if the CIB branch will not be overloaded.

#### **Reducing the load (reducing the consumption) of CIB.**

The most of peripheral CFox modules are powered from CIB. There exists several modules like C-HM-1121M (supplied from the mains 230VAC) or C-OR-0008M (optionally powered from external 24 or 27,2 VDC), which enables to connect the higher amount of inputs outputs on the CIB without need to be supplied from CIB.

#### **Dividing large installation among more CIB branches.**

In case of large installation application with more CIB buses it is useful to take it into account the consumption of each module during the planning the wiring topology. It is a good practice not to wire all relay modules on one CIB branch and on the other one only temperature sensors. In such case the first branch will be overloaded while the power capacity of the second one will stay not fully used. It is always useful to spread the load over all branches to achieve the reliable compliance of topology, amount of modules and load of each CIB. It is a good practice to save the capacity of each branch for the future extensions.

### 3.1.3 CIB master CF-1141

Master module CF-1141 provides the mastering of 2 CIB branches each for max. 32 slaves. CF-1141 provides identification, addressing, configuration and regular operation of CIB peripheral modules. Also it provides the data handling and data transfer to Foxtrot over the TCL2 system bus (see [chap.3.3.](#)) Max. 4x CF-1141 can be connected to one Foxtrot basic module each for 2x CIB masters. Configuration of CF-1141 can be done either from the free programming tool MOSAIC or from parametrization SW – FoxTool. Master module provides also the auto-diagnostics, which enable to analyze the status of module, communication statistics etc. CF-1141 has also the terminals for direct connection of backup accumulator. It simplifies the wiring of the backup system, which can supply the CIB master as well as all peripheral modules on the CIB bus during the fail of mains. All inputs and outputs are protected against the short circuit by the reversible electronic fuse.

The front panel contains one two-color LED indicator. The green indicates the bus operations, the red one indicates the failure of the module. There is also the rotary encoder to set the module address on the TCL2 system bus.

The master module is supplied either from 24VDC or 27,2VDC in case of backup. It contains the circuits to couple CIB to the standard power supply. No additional coupling modules are necessary in this case. The power consumption of the master module is sum of its own consumption and the consumptions of all slave modules on the both CIB branches.

The same rules for the choice of the power supply can be used also for CF-1141. The max. current of each branch is 1A.

For this total consumption the adequate power supply should be dimensioned and coupled for each branch.

If CF-1141 is placed in the same cabinet together with the basic module it is possible to power them from one power supply (with or without backup). In such case the backup accumulator is to be connected only to one of them – usually to basic module.

The connection of CF-1141 module is on the figure.

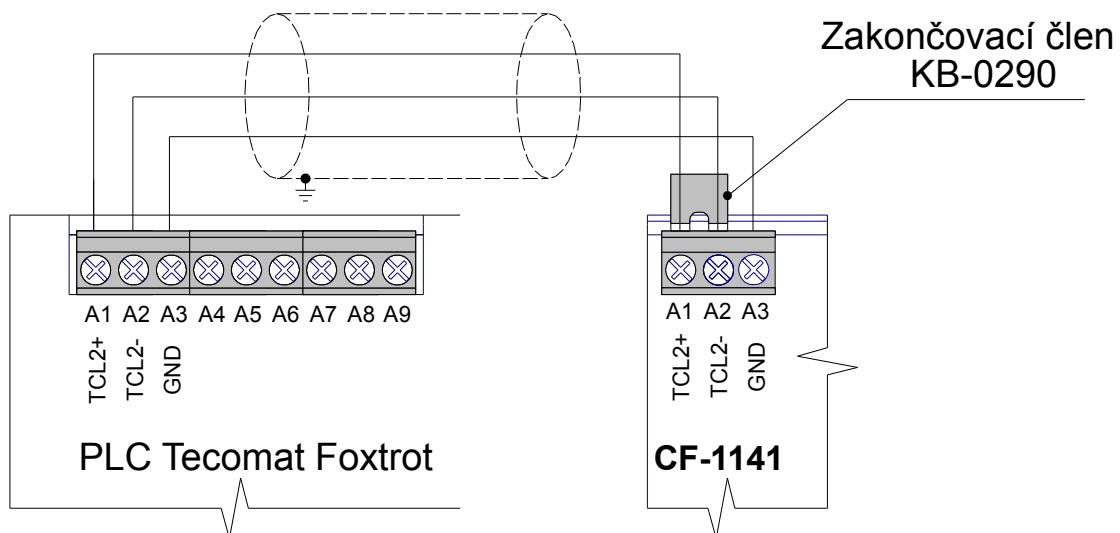

Fig. 3.1.3.1. Connection of CF-1141 module to Foxtrot basic module.

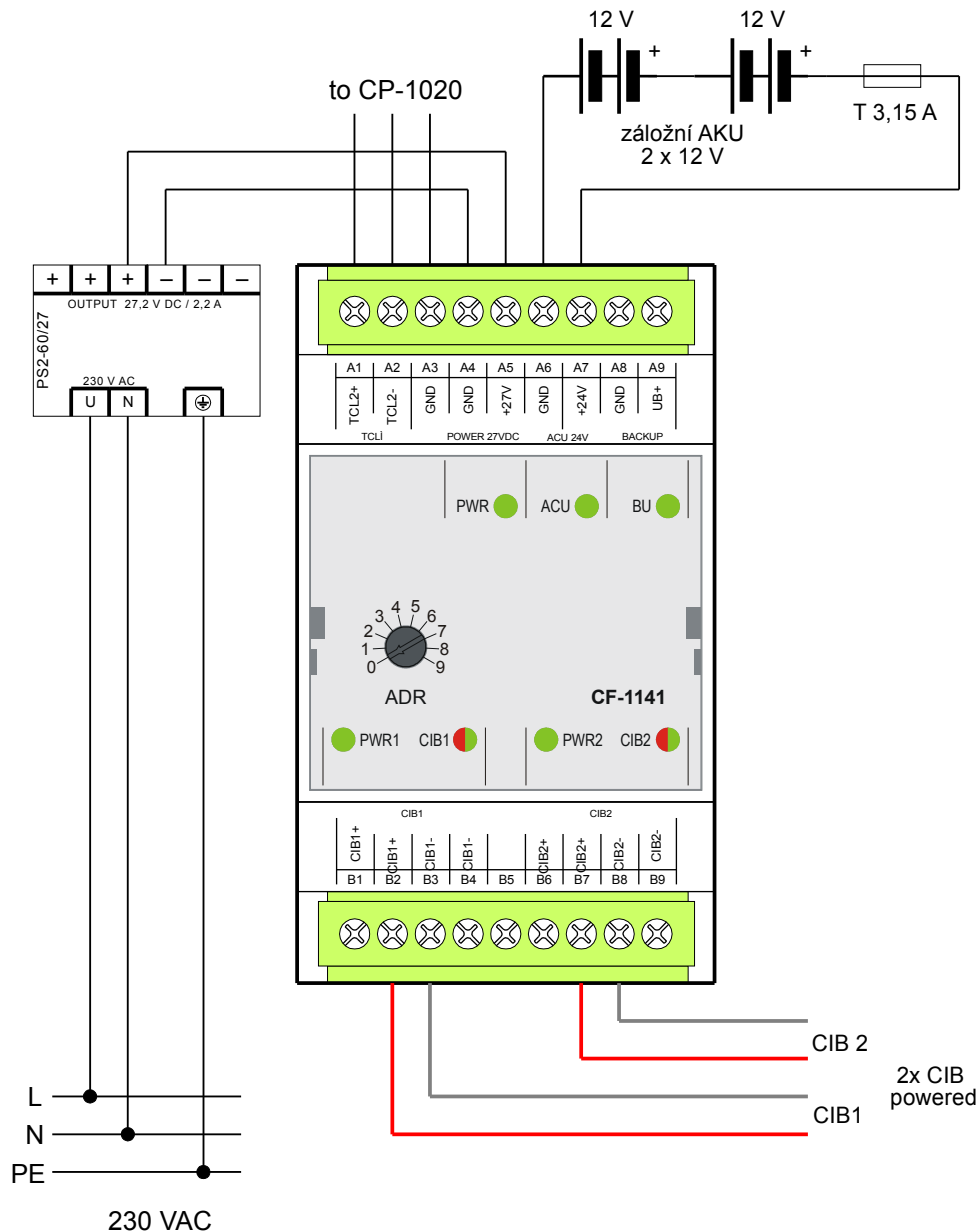

Fig. 3.1.3.2.2. Connection of CF-1141 with backup accumulators.

Notes:

- 1) We recommend a PS2-60/27 - stabilized power supply of 27,2 VDC, complying SELV. Power consumption of CF-1141 is the sum of its own power (typically 1W) and the total wattage of all connected modules CFox on both of CIB branches.
- 2) There is the outputs of both powered CIB branches on terminal B for a maximum current of 1 A for each branch.
- 3) The backup accumulators should be encapsulated lead-acid type with the capacity from 7Ah up to 28 Ah. The capacity is calculated from the total consumption and the period which the system should be backup.
- 4) In case of current presence of both CF-114 and the Foxtrot basic module, the backup output (A8, A9 terminals) can be used to power both of that modules. Backup accumulator is connected only to CF-1141.

### 3.1.4 CIB coupling to the power supply – C-BS-0001M coupler

The coupler C-BS-0001M enables the proper coupling of the the power supply to CIB separating the communication pulses of all CFox modules from the power supply.

Module is available in the 1M box for DIN rail mounting. On the front panel the green LED indicates right voltage on the module output. The output is protected by the reversible electronic fuse against the short-circuit on the CIB.

C-BS-0001M is designed to exceed the power of internal coupler in the CP-10x4/10x5/10x6/10x8 basic modules. They have limited capacity to power full loaded CIB or for older Foxtrot basic modules which have no coupler inside.

Maximum current for CIB powering from this module is 1A. For this load the power supply has to be dimensioned.



### 3.1.5 CIB surge protection – DTNVEM 1/CIB and DTNVE 1/CIB

In case the CIB installation has the potential of over-voltage appearance e.g. the parallel layout along the lighting conductor or the part of CIB is wired outside the building, it is NECESSARY to use the surge protection properly. Since the unique features of CIB bus, only special surge protections can be used. Using the other types can essentially reduce the reliability as well as the functionality of CIB installation.

#### For CIB bus there are two surge protections available

Both of them have the identical electrical characteristics, they differ only by form factor.

**DTNVEM 1/CIB** 1M housing for DIN rail mounting with the screw-type terminals.

**DTNVE 1/CIB** for flush or under cover installation with the 10 cm isolated wire outlets.

Surge protection DTNVEM 1/CIB is the basic protection element for the CIB . It protects against the over-voltage which can appear only in the bus. It does not substitute protection of all the control system. The main surge protection of the whole system is always the protection of power supply i.e. properly designed and installed protection of 230 V AC power supply. The protection the main power supply has to be inherent part of each system design. All the principles of installation of surge protection as they are generally known should be used to protect the 230 VAC power supply.

DTNVEM 1/CIB is Surge Protection Device (SPD) according to EN 61643-21 (category A2, B2, C2, C3, D1) designed to protect CIB against lightning currents and surges. The recommended location is the input line from outside into the building, as well as on border with other LPZ (Lightning Protection Zones according to EN 62305) and close to the protected device, so that the cable length between the over-voltage protection device and the protected equipment should be less than 10 m.

DTNVEM 1/CIB consists of a base and replaceable module that contains the protection itself. The base is still attached so in case of inspection or damage one can handle only with replaceable module. The base is not removable so the CIB wiring is not interrupted.

The protection is designed for continuous current up to 0.5 A. It is necessary to ensure in the project design that this current will not be exceeded.

DTNV 1/CIB engages output toward the protected equipment.

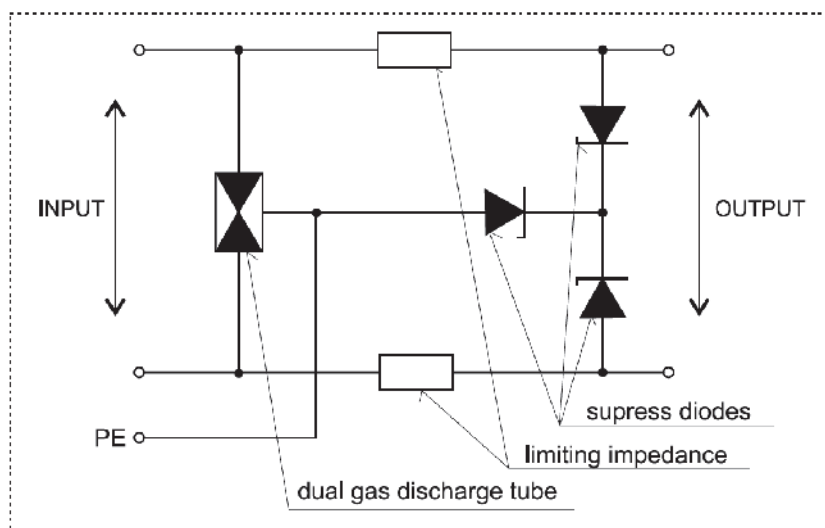

Fig. 3.1.5.1. Internal circuit of surge protection DTNVEM 1/CIB (same is for DTNVE 1/CIB)

The DTNVEM 1/CIB surge protection always should be in front of the part of the bus we want to protect. So we need to protect all parts of the installation leaving the zone ZBO1, or installing along the large metal parts of buildings that are in zone 0, eg. lightning conductor). We must protect individually all parts of each installation, which the above theorem applies.

In Figure 3.1.5.2 we have outlined an example where the installation is done with CIB inside the house. The main part of the installation ③ is located inside of the protected object and its protection is implemented on the system power supply 230 V (protection covers the entire application - a central unit and bus unit).

Part of the units ② are located in an adjacent building - garage, which leads the CIB bus cable laying in the ground. It is necessary to install protection always at entry point into the building. So that both parts of the installation are protected against ingress of over voltage which may occur in the cables in the ground.

One unit is located under the roof ① (eg, wind speed meter). CIB wiring goes along the lightning rod mounted outside on the perimeter wall. Suitable place for surge protection is on the end of parallel layout with the lightning rod. The unit ① - is unprotected, but the rest of the application is protected properly.

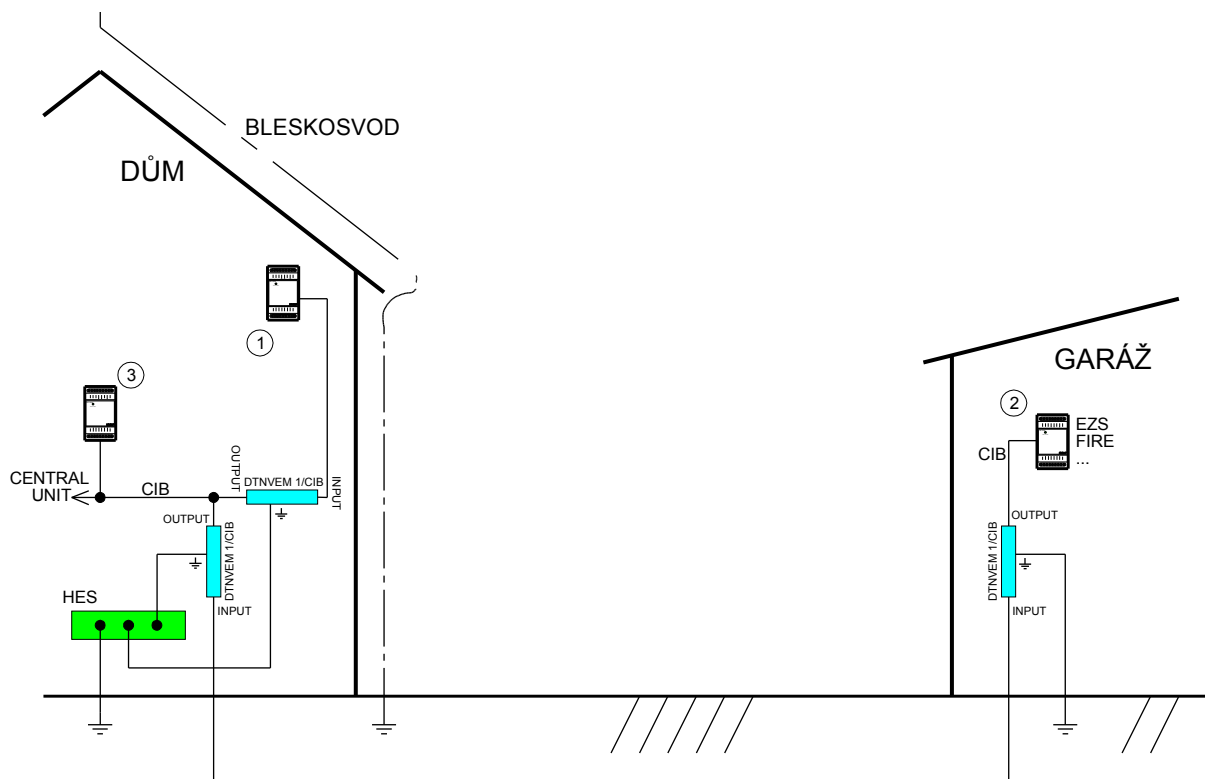

Fig. 3.1.5.2. Typical protection variants by DTVN 1/CIB

## 3.2 RFox – principles of design and installation

RFox is wireless mesh network operating like a bus. It is operated in accordance with the ERC RECOMMENDATION 70-03 RELATING TO THE USE OF SHORT RANGE DEVICES (SRD). For operations in unlicensed radio band 868 MHz no additional permission is required. RFox bus is always composed of one master and up to 64 slaves - peripheral I/O modules. Master of the network can be implemented as an external DIN rail mounted module connected by TCL2 system bus. Wireless peripheral modules are available in different form factor for the interior, for mounting on DIN rail in cabinets, hand-held remote controls, ....).

### 3.2.1 RFox - basic characteristics

RFox network is designed to be compliant with the ERC Recommendations mentioned above. The system is designed not to increase the load of the environment by the additional radio wave operations. Transmit power is about 3.5 mW (maximum allowed is 25 mW) and the system is designed to minimize radio operations to a minimum time. It uses low power to achieve higher battery life cycle of battery-powered modules. Minimal transmitting power also eliminates an impact on human health. Standard system configuration satisfies the maximum 1% duty cycle, although due to the implementation of the LBT (listen before talking) the duty cycle is not limited. It uses the multichannel operations and there are 8 channels as a standard available in the frequency range g1 (868.000 to 868.600 MHz, according to general authorization).

### 3.2.2 RFox – functions, configurations, properties

Communication among RFox master and RFox slave is supported for star and mesh topology

Star topology means the direct wireless access between master and slave, master always communicates with all slaves directly

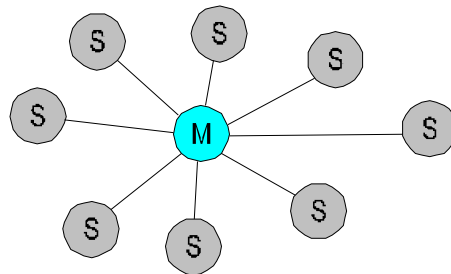

Fig. 3.2.2.1 Example of star topology

Mash topology means such placement of slaves, where the master has direct access only to some slaves. The other slaves are accessible only through the routers. Router (repeater) receives the RF packet, and transmit it in the air. Using the routers it is possible to increase the basic range of RFox master accessibility.

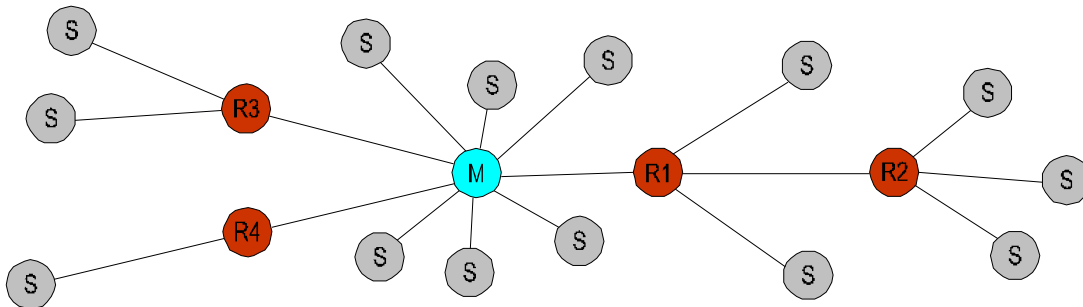

Fig. 3.2.2.2 Example of Mesh topology.

In one RFox mesh network max. 4 routers can be used. Transmitted RF packet has to reach its destination using max. 5 hops. Each hop increase the delay between the transmitting and receiving the RF packet. It means delay between command and action.

Any RF module with permanent operations can works as router as well. The router function can be assigned to any RF module during RFox network configuration procedure.

Concerning the regular operations, there exist RFox modules with continuous operations and modules with interrupted operations.

Modules with continuous operations are able to follow the master commands anytime. They are usually continuously powered.

Modules with the interrupted operations (usually battery operated) stay the most of time in the sleep mode. In the sleep mode they do not answer on the master commands. They operates only for a short time. They are waked up by the user defined function as the push of the button or by time schedule.

### 3.2.3 RFox master RF-1131

RFox master implements the wireless communication with peripheral modules and transmits the data via TCL2 system bus to the Foxtrot basic module. Master is available in two variants. Either as an internal part of Foxtrot basic modules CP-102x and CP-103x and referred internally as RF-1130 or as an external peripheral module on TCL2, referred as RF-1131. We recommend to use external master since it gives much better result concerning the distance of access.

One RFox master can handle up to 64 peripheral RF modules. The Foxtrot basic module can control one up to 4 external masters RFox, together 256 wireless modules.

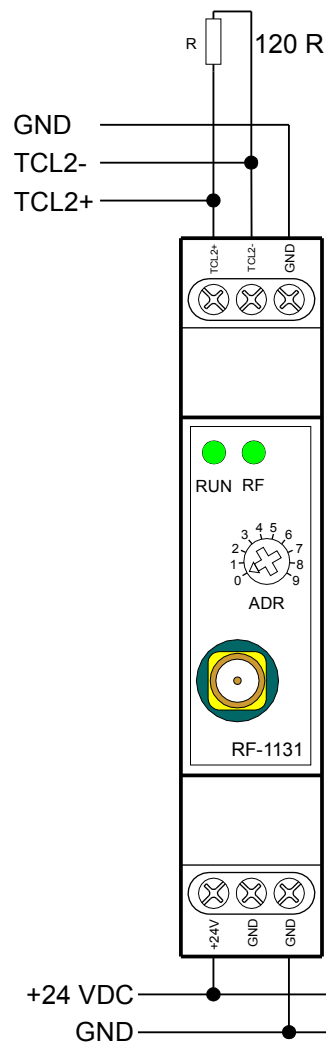

Fig. 3.2.3.1 Connection of terminals of RFox master RF-1131

External master RF-1131 is to be connected to the PLC via TCL2 system bus on the A1 to A3 TC terminals referred as TCL2.

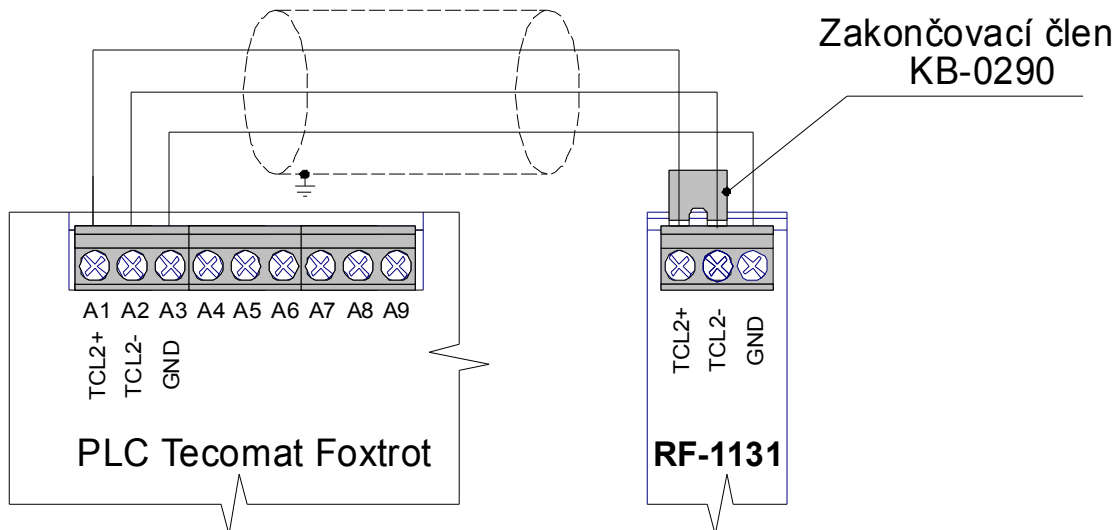

Fig. 3.2.3.2 Connection RF-1131 module to PLC TECOMAT Foxtrot

At the PLC side the TCL2 bus has the impedance terminal inside the PLC. On the side of the RF-1131 module is necessary to fix the termination impedance. Completing can be done by KB-0290 (TXN 102 90, 120 $\Omega$ ) connected between the terminals TCL2+ and TCL2-. The terminator is a part of Tecomat Foxtrot delivery. If the communication line Termination has to be always done at the most remote module on the whole line in case of multiple modules on TCL2!

#### Module power supply

RFox master requires 24VDC to be supplied. It can be used the same power supply for both basic module and for external RFox master. Internal RFox master is supplied directly from the internal circuits of the basic module.

#### RFox antenna

To enable the access to wireless RFox network the screw type antenna with SMA coaxial connector should be used. The small antenna fixed on the module can be used. Also the external antenna with the connector on the cable can be used. This second one enables to place the antenna outside the metallic cabinet and also to find the best place for radio waves.

#### 3.2.4 RFox router R-RT-2305W

R-RT-2305W is one purpose router which increases the range of access of RFox network by means of the mesh topology.

Router is a plug-in version for 230VAC power outlet and has one green LED indicator

The router provides receiving the RF packet and its subsequent RF packet forwarding on. In one RFox network (under one RFox master) you can use a maximum of 4 routers.

The router form factor of an adapter into an outlet 230VAC and besides the plug has no other connections.

### **3.3 TCL2 system bus – principles of design and installation**

Detailed description of TCL2 characteristics and the rules for wiring you can find in [documentation \[4\]](#).

The modules UC-1204 – Open Therm communication module, or UC-1203 – MP bus for drives by Belimo which can be used in building or HVAC automation are also described in [documentation \[4\]](#).

## 4 Heating

Foxtrot system allows to realize solutions from simple one such as regulation and control of a gas boiler with radiators through complex assemblies with floor convectors, underfloor heating up to complex managing of multiple sources of heating like heat pumps, gas boilers, automatic boilers for liquid and solid fuel, solar hot water systems and also comfortable heating and cooling with fan coil units, ceiling cooling, remote controlled air conditioning units as well as controlled ventilation with centralized or decentralized recuperation.

### 4.1 Hot water heating – valve control

The standard radiator valves can be controlled electrically. The scope of such valves is very wide and they are manufactured in many types of different size, power, opening and closing time, of different control, power supply, normally open or closed with the possibilities of various screw toward the valve and toward the price.

CIB powered drives C-HC-0201F-E or C-HC-0101F can be used for standard applications of hot water panel radiators. These drives are powered directly from the CIB bus. They use the motor with proportional 0-100% setting of the valve position.

C-HC-0101F has an extremely low power consumption about 0.6 W during the positioning. It is mechanically identical with the RFox drive R-HC-0101F.

C-HC-0201F-E is a smaller drive, the positioning takes more power than the previous one. It allows connect 2 external sensors (eg. Temperature and window contact).

In case of wireless installation, the battery powered valve RFox R-HC-0101F should be used. This drive is powered by one or two AA batteries 3.6 V.

Other possibility is to use standard electrically controlled on/off drives and switch them by relay outputs or by analog output 0÷10V.

The 24VDC voltage level for control is preferable due to the electrical safety – access of children. The disadvantage of this version is the necessity to install wires for 24VDC power.

The 230VAC is available practically everywhere and no 24VDC has to be wired.

The proportional controlled valves 0÷10V enable better feedback control but the price is rather high.

#### Alpha AA drives are recommended.

These drives have large range of adapters for standard and less standard radiator valves on the market. They have smart design and several versions of control. The list of drives available:

AA Alpha 230 NC	230VAC powered, normally closed
AA Alpha 230 NO	230VAC powered, normally open
Alpha AA 24V DC/AC NC	24 VDC/AC powered normally closed
Alpha AA 24V DC/AC NO	24 VDC/AC powered normally open
Alpha AA 0-10V proportional	24 VDC/AC powered, control signal: 0 to 10V

Selection of the operating voltage is determined according to the customer needs.

The choice between the drives normally closed or normally open depends on customer preferences to minimize power consumption (controlled radiators in the insulated house will be closed most of the year so the normally closed drives bring higher efficiency), or the customer requires normally open valves so during the blackout the valves stay open.

The drive and adapter must be ordered according to the specification of radiator valve manufacturer.



#### 4.1.1 CIB powered drive C-HC-0201F-E

C-HC-0201F-E is CIB powered drive and can be used for proportional control of radiator valve. The drive is equipped with auxiliary 2 analog/binary inputs. It has standard screw M30x1,5 for mounting on the valve. For other mounting dimensions reduction accessories are available as a separately ordered items.

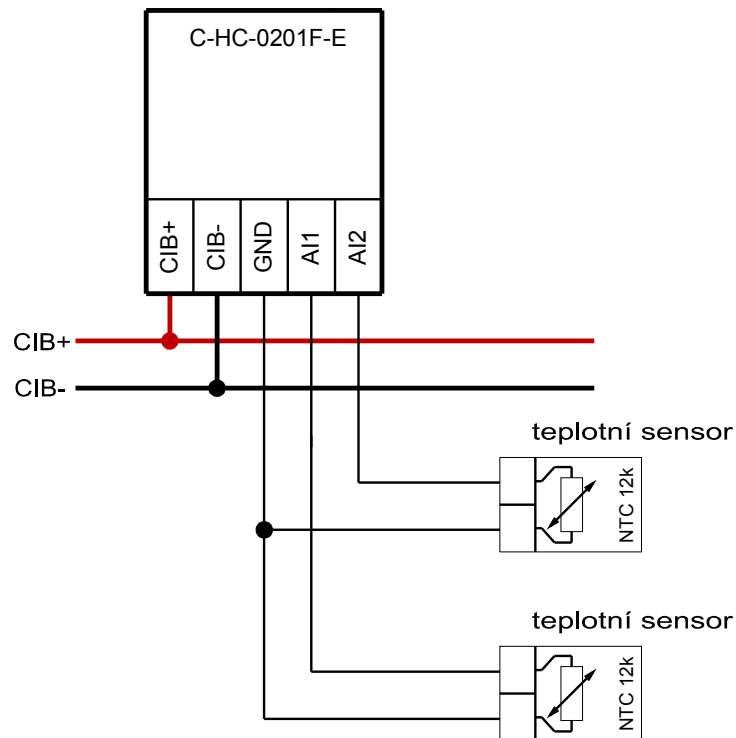

Fig. 4.1.1.1 Example of wiring – Motorized CIB drive C-HC-0201F-E for radiator valves.

#### Notes:

- 1) Motorized drive has two inputs configurable as analog inputs for temperature sensors or as two digital inputs for dry contacts e.g. window or door contact. So the temperature sensor and window contact can be connected at the same time.

#### 4.1.2 Alpha AA - Two-position drive controlled by relay output

To switch this drive any relay output in the system can be used. The typical consumption of the drive is about 3W when energized. As a local switch of drive C-IR-0202S module is suitable. Equipped with the 3A and relatively quiet relay and with 2 general purpose inputs for temperature and window sensors it is smart solution. Be careful about the noise of relay switching in the bedroom.

Any relay output like outputs on the C-HM-1113, etc. can be used to switch the two-position drive from the centralized cabinet.

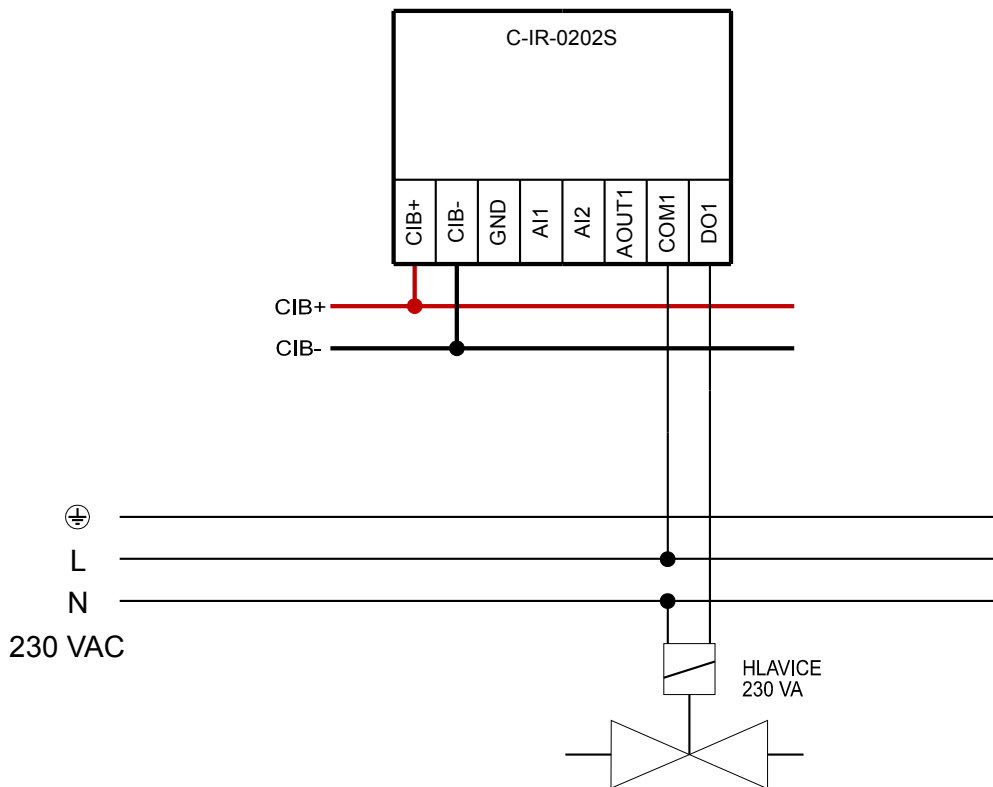

Fig. 4.1.2.1 Connection example of two-position drives for radiator valves.

##### Notes:

- 1) Alpha AA drives (230 VAC i 24 VDC/AC) have the continuous consumption about 1,8 W. Power supply and circuit protection must be dimensioned for peak current during switch on (up to 300 mA per one drive for up to 2 minutes). Also other electrically controlled actuators of most manufacturers have similar consumption.

Basic parameters of the two-position drives Alpha AA:

Termodrive ALPHA AA	Supply Voltage	Function	Peak current max.	Continuous current
<b>AA 2004 / 230 V NC</b>	230 V AC, +10% .. -10% 50 ÷ 60 Hz	Normally closed	300 mA for max. 200 ms	8 mA
<b>AA 2104 / 230 V NO</b>		Normally open		
<b>AA 4004 / 24 V NC</b>	24 V AC, +20% .. -10% 0 (DC) ÷ 60 Hz	Normally closed	250 mA for max. 2 min.	75 mA
<b>AA 4104 / 24 V NO</b>		Normally open		

### 4.1.3 Alpha AA 5004 - Proportional drive controlled by 0÷10V signal

This drive can be controlled by any analog output 0 ÷ 10V of system Foxtrot. To control the drive locally, the C-IR-0202S seems to be most appropriate. It is equipped with analog output (0 ÷ 10V) and two inputs for room temperature and for the window contact. Supplying more drives from one common source of 24VAC it is highly recommend to take care about the galvanic connection of the analog outputs of each CIB module and the 24VDC power supply for drives. The negative potential of the power supply is connected with negative potential of the CIB bus through the analog output circuits. It is necessary to keep the minimum voltage difference between that two signals. Use the same cable topology, sufficient cross-section of CIB wires as well as of 24VAC power supply wires.

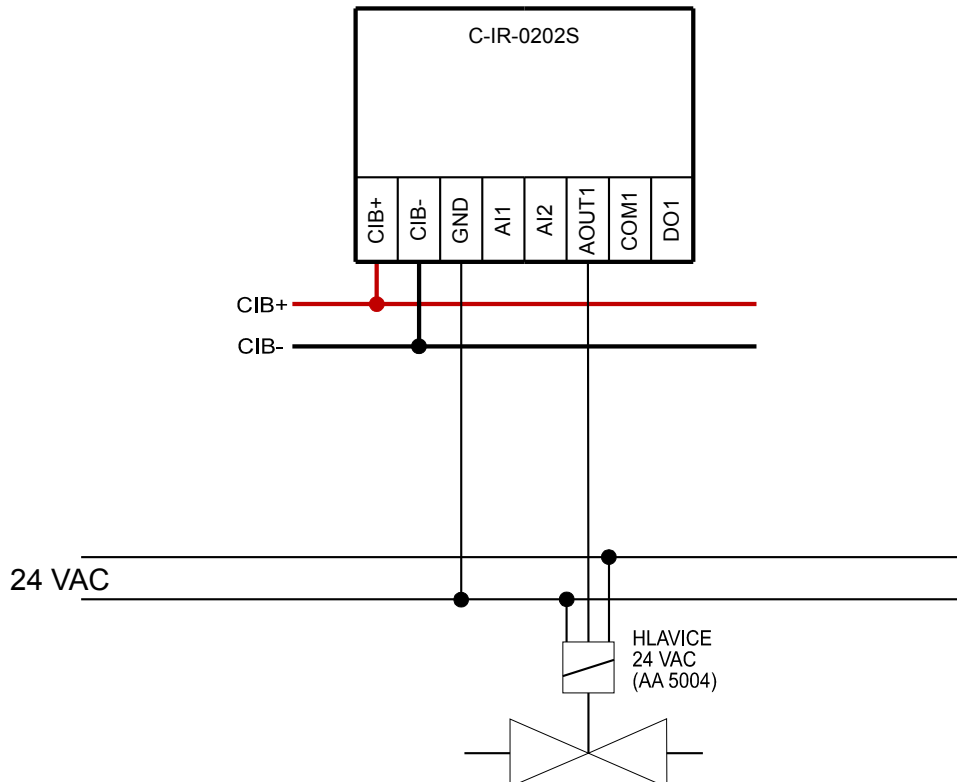

Fig. 4.1.3.1 Connection example – proportionally controlled drive for radiator valve.

#### Notes:

- 1) For control of AA 5004 drive it is necessary to take care about the continuous consumption about 1,8 W per drive (Peak current 200 mA for max. 2 minutes per each drive)
- 2) Input impedance of analog input of AA 5004 drive is 100 kOhm.
- 3) If you want to supply more drives from a common 24VAC power supply, you must take care about the galvanic connection of the power supply and CIB over analog input of the drive. CIB bus and power supply 24 VAC must have strong wires and be installed together.
- 4) For the bigger cable length like tens meters, the motorized CIB drives or two-position drives should be used.

#### 4.1.4 Alpha AA 5004 – two-position drive controlled by RCM2-1

The RCM2-1 has one SSR (Solid State Relay) output, which enables direct control of the valve drive (Alpha AA) powered by 24V AC/DC. Max. current is 600mA. The output has galvanic isolation from other circuits of RCM-1.

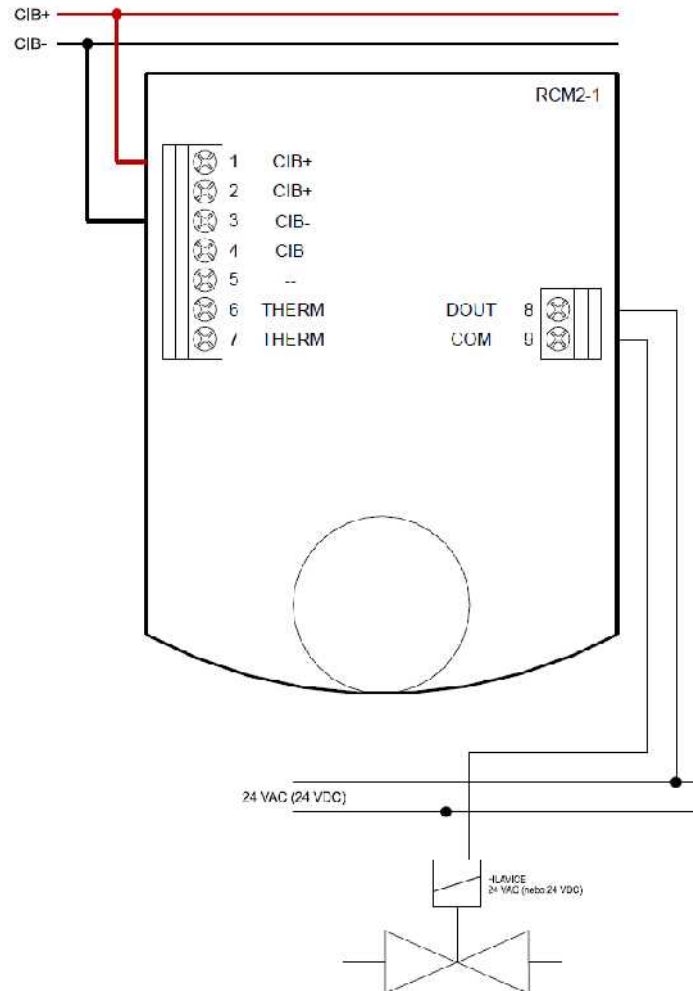

Fig. 4.1.4.1 Example of two-position drive of radiator valve controlled by RCM2-1

#### Notes:

- 1) The SSR output is only for low safe voltage of 24VAC/DC. The output load can have any polarity. It is possible to use SSR output in the same way as the relay contact.
- 2) To switch bigger load than 600mA (e.g. more drives) SSR can control standard auxiliary relay mounted in the flush box, which can switch bigger load.

## 4.2 Underfloor heating -hot water

Usually two-position drives located in the splitter can be switched by several types of modules. It depends on the number of branches and/or on other requirements for measurement and control. Example of control of a 6-splitter actuators is on the following figure. It is possible to place the C-HM-0308 along the splitter.

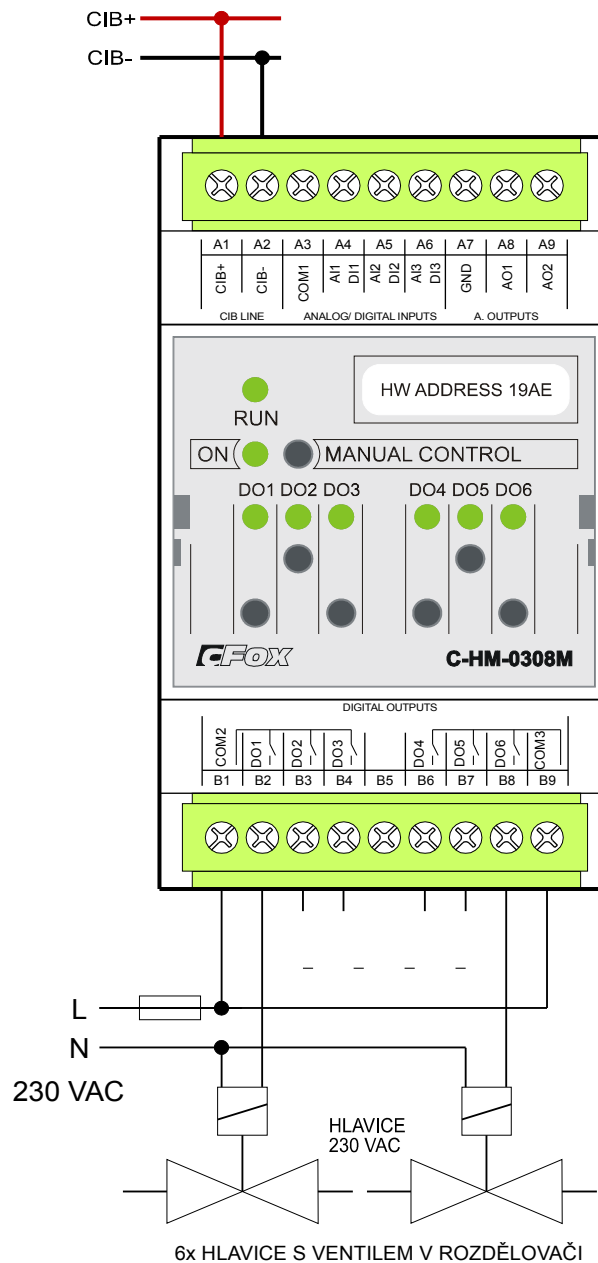

Fig. 4.2.1 Example of hot water underfloor heating with 6 valves for 6 branches. The C-HM-0308M module is used

### 4.3 Underfloor heating - electrical

Heating cables or heating mats must be switched by relay outputs according to the switched current. The relays of C-OR-0202B for flush mounting can be used with the possibility of simultaneous measuring of floor temperature. Also the C-OR-0008 can be used to switch up to 8 branches. It can be placed in the distribution cabinet next to circuit breakers for individual heating branches. Also RFox wireless module R-OR-0008M can be used powered by 24VDC from power supply DR-15-24. For wireless control RFox network must be installed.

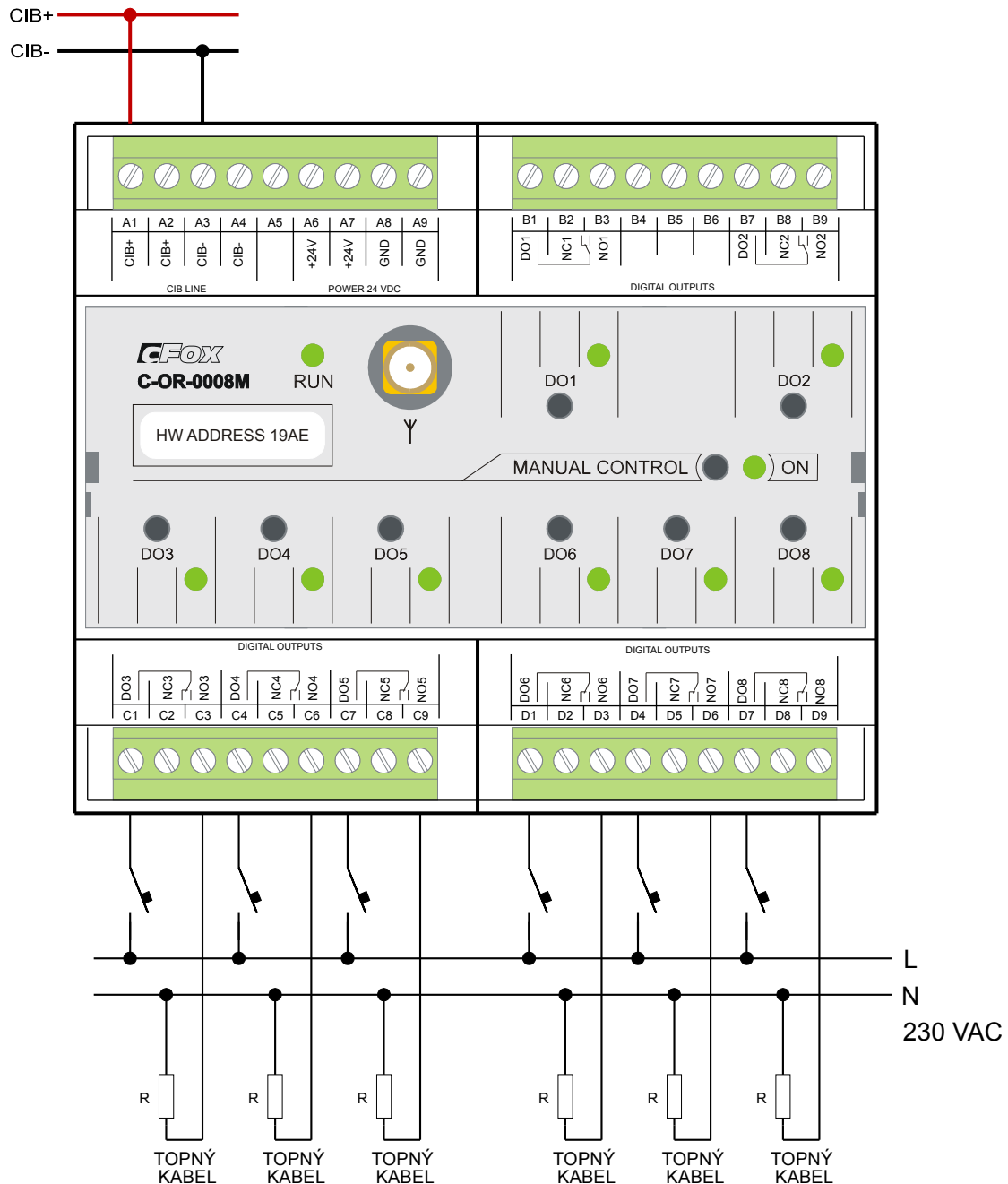

Fig. 4.3.1 Example of electrical underfloor heating switched by C-OR-0008M

#### Notes:

- 1) Protection by circuit breakers have to be dimensioned according to the power of each heating cable, max. 16A per branch.

## 4.4 Floor convectors – proportional control

### 4.4.1 Floor convectors ISAN - with 24VDC EC motors

Module C-FC-0024X allows to control several convectors equipped with 24V EC motors by the analog signal 0 to 10V or by PWM – Pulse Width Modulation. The module can control also two electric drives of hot and cold water, it can measure up to 3 temperatures. Each input can be configured to measure temperature or dry contact – e.g. window contact.

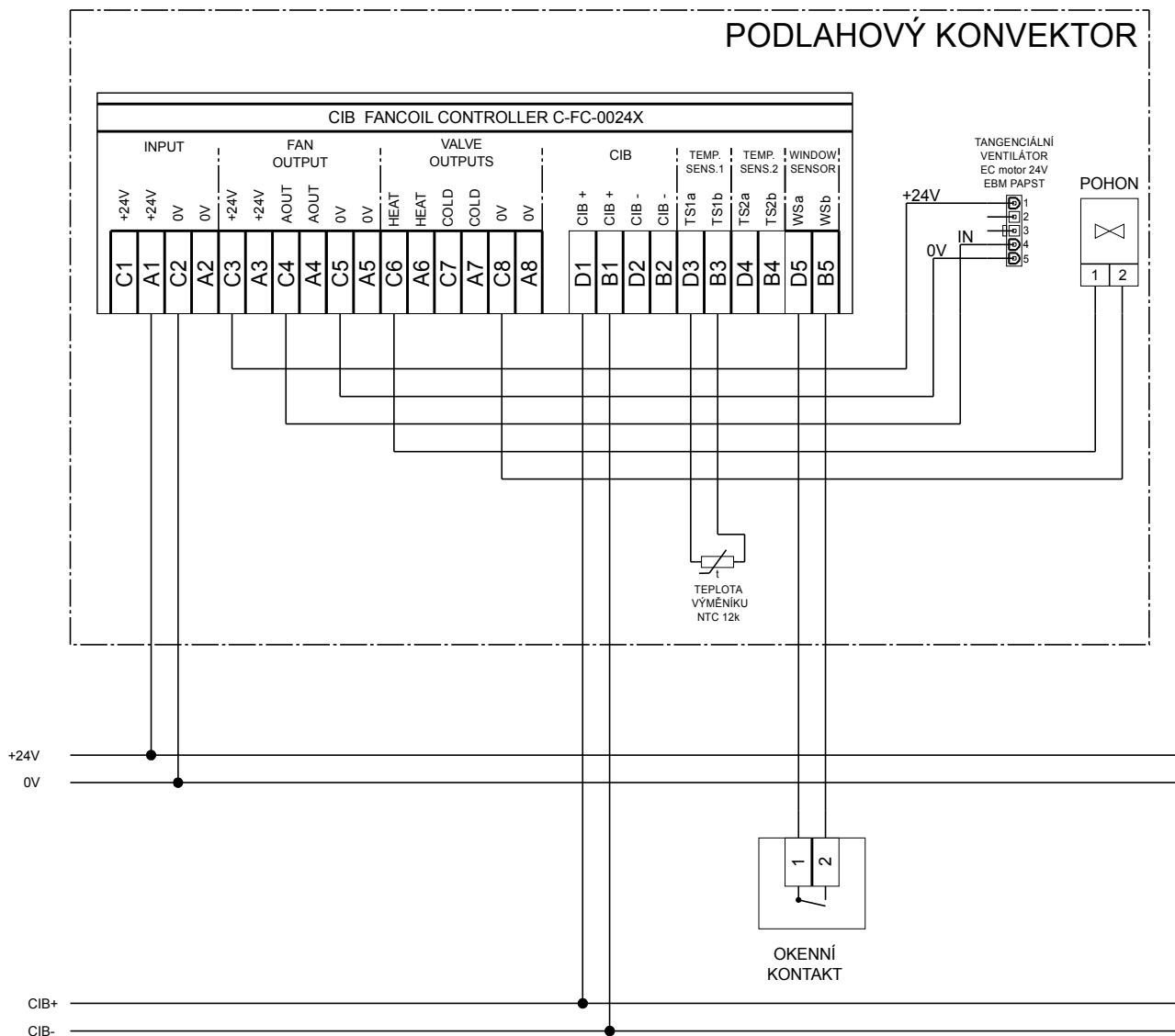

Fig. 4.4.1.1 Example of two-pipe convector by ISAN with EC motor by EBM Papst

#### 4.4.2 Floor convector MINIB – connection to the Foxtrot system.

Convector is equipped with only the control block EB. Heating valve is mounted in a splitter or can be mounted directly in the convector. Convector is not equipped with additional sensors like frost protection. Convector with the EB controller is powered by 12V AC from TT100 transformer (230 V/12 V AC, 100VA). In this example the ALPHA AA4104 drive is used (24V, NO).

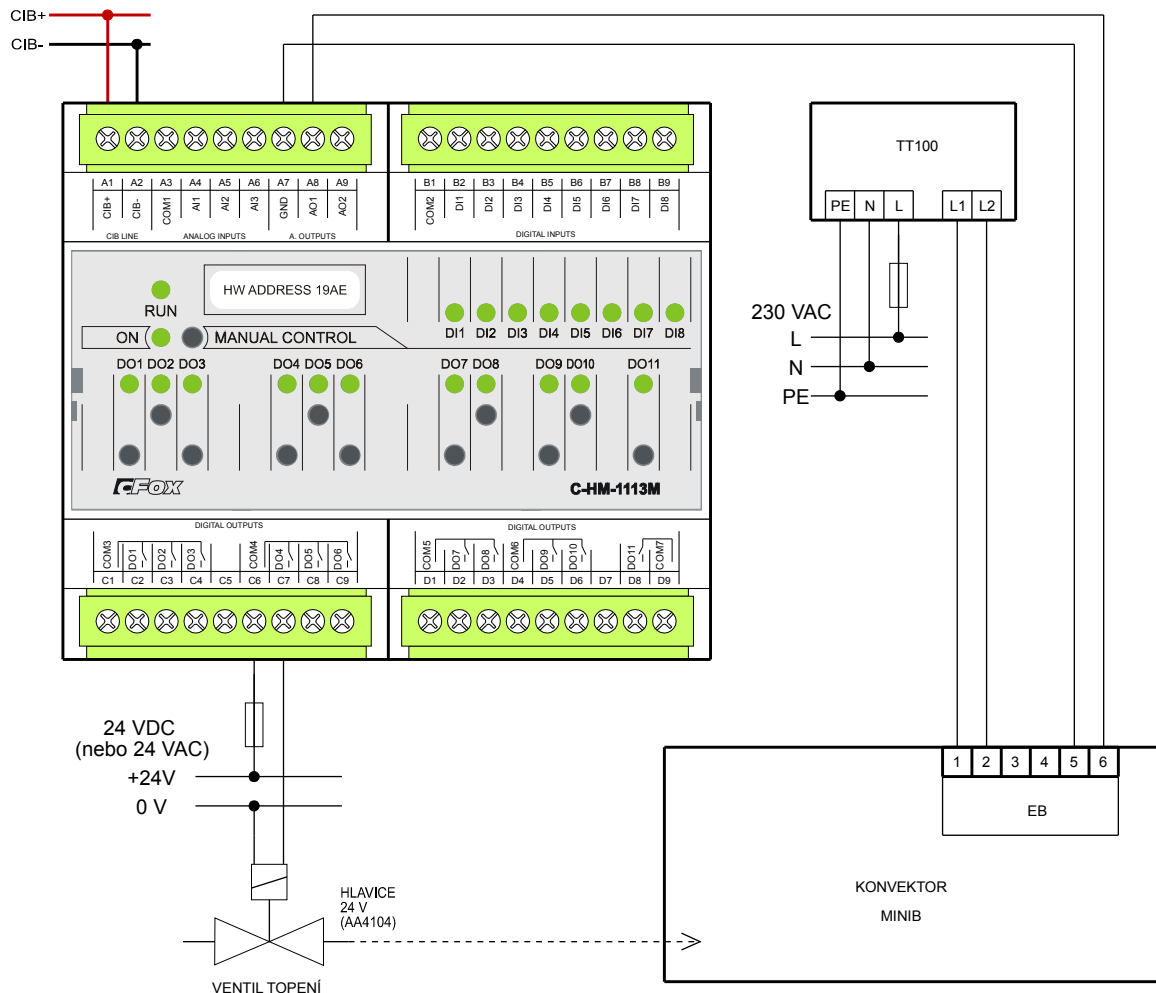

Fig. 4.4.2.1 Example of control of the MINIB convector equipped by the EB control block



## 4.5 Fan Coils

Fan coil units are manufactured in various designs from the control point of view. Following figure shows the typical configuration with the 3-speed fan, two-position drives for heating and for cooling circuit. The figure shows also how to connect the condensation sensor and two temperature sensor. Additionally C-HM-0308 module can provide also the control of proportional speed drives, proportional speed control of EC motor by two (0-10V) outputs etc.

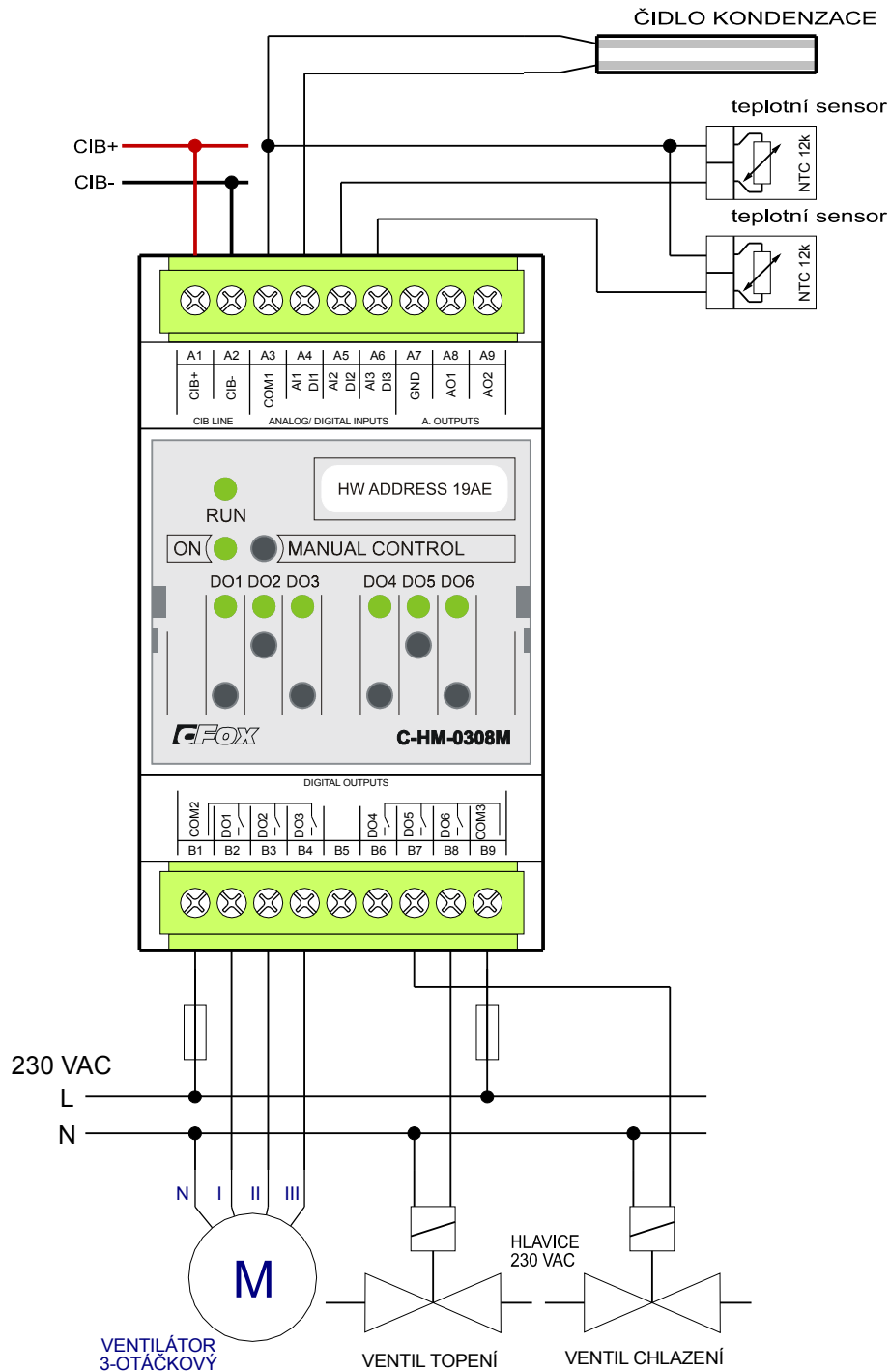

Fig. 4.5.1 Example of control of four-pipe Fan Coil with 3-speed fan.

#### 4.5.1 Fan Coil AERMEC FCXI – connection example.

Inverter fan coils AERMEC FCXI and FCLI are available in 2- and 4-pipe design. Also FCXI-P version is on the market without housing just for mounting into air ducts in the ceiling or in the false wall. The installation in the parapet niche is also possible. Fan-coil AERMEC FCXI and cassette fan coil FCLI allows proportional control of fan motor speed (0 – 100%). Thus the smooth air flow, cooling and heating is enabled.

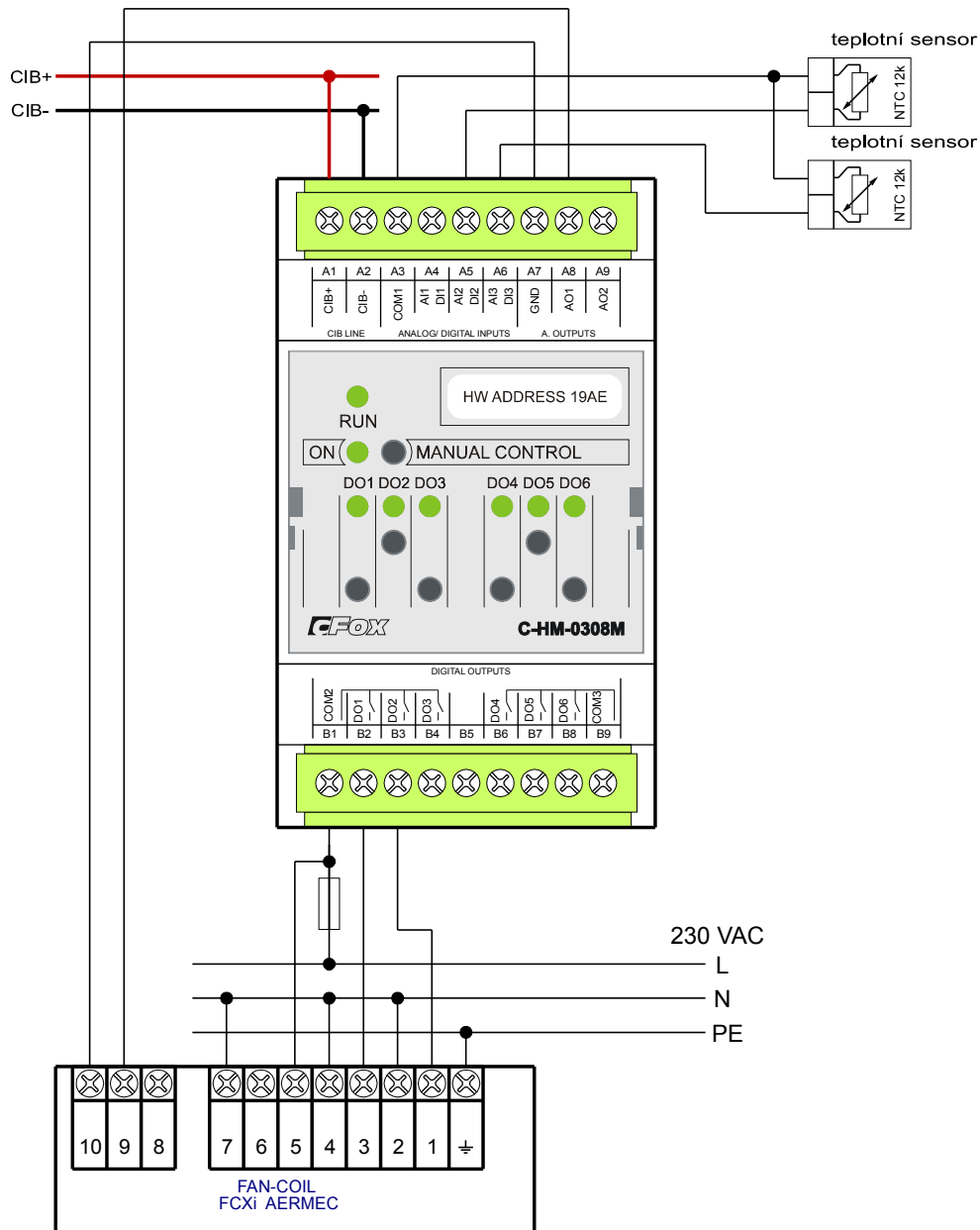

Fig. 4.5.1.1 Example of connection of FCXI fan coil by AERMEC

#### Notes:

- 1) For 2-pipe fan coil unit FCXI only the valve actuator is connected to terminals 3 and 4 is controlled.
- 2) For 4-pipe fan coil unit the heating actuator is on terminals 3-4, the cooling terminal is on terminals 1-2, drives are powered from 230 VAC.

## 4.6 Heating - Boilers

**Boilers** for gas, automatic pellet, automatic coal, etc. can be controlled by any relay output in the system Foxtrot. In the more complicated set of heat sources it is recommended to limit or to avoid the own "intelligence" of the boiler like ekviterm heating curve, etc. The optimal control algorithm of the boiler should be discussed with the specialist and should be integrated in the Foxtrot system. This allows you to set, to change, to monitor the behavior of the whole system directly in the Foxtrot, including all remote management tools, supervision and service.

In a similar way you can control also heat pumps, which do not have intelligent communication with the control system of the house. The room thermostat input can be used to master the heat pump.

Boilers equipped with **Open Therm** interface can be controlled using the UC-1204 module. Example of connection to the Thermona boiler equipped by IU05 interface including connection principles is [documented in \[4\]](#).

## 4.7 Heating – Heating pumps

**Heat pumps** equipped with a communication interface can communicate with Foxtrot usually by the same interface. In case of heat pump driven by Foxtrot as an inherent part of heat pump, it can be connected to an intelligent home control system via Ethernet. It can also be used for better control and sharing parameters. E.g. it is possible to add the setting parameters of heat pump to the website of the house and handle all as one entity. The data transfer between the heating pump and Foxtrot managing the whole house must be coordinated with the heat pump supplier or manufacturer.

## 5 Ventilation

Ventilation and heat recovery units are supplied with its own controller, which often can not be integrated into building management system. It is therefore preferable to control ventilation units with the heat recovery directly by Foxtrot. Foxtrot is equipped with a range of input/output modules suitable for this purpose. Library of function blocks ready to control ventilation, heat recovery units, fan coil units, etc. is expanding step by step. The advantage of this solution is the flexibility of hardware where custom control of ventilation can be combined with other technologies. The SW and HW of the control system can be configured accordingly.

List of I/O modules for different ventilation systems:

### Fans:

Discrete speed control of 230V motors	relay modules, eg. C-HM-0308M
Variable speed of 230VAC asynchronous motor - embedded	C-FC-0230X
Variable speed of 24 VDC EC motors, embedded	C-FC-0024X
Variable speed of 24 VDC EC motors, 0÷10V control	Eg. C-HM-0308M
Variable speed of motors with inverters, 0÷10V control	Eg. C-HM-0308M

### Sensors:

Temperature sensors	Eg. C-HM-0308M
Condensation sensors	C-HM-xxxxM
CO <sub>2</sub> sensor in interior design	C-AQ-0001R

### Servo-drives:

3-point controlled servo-drive 230V or 24V	Relay modules eg. C-HM-0308M
Analog 0÷10 V controlled servo-drive	AOUT, eg. C-HM-03308M
Damper actuator, 1-point control	Relay modules eg. C-HM-0308M
Servo-drive with protocol MP-Bus	UC-1203

It is also possible to control the electric heater by 16A relay outputs, e.g. C-OR-0008.

It is also possible to read inputs from sensors (filter, etc..) from the remote control (e.g., manual control of the bathroom, etc.)

## 5.1 Heat recovery system - Fan speed control.

The figure shows an example of control of heat recovery unit with two fans with EC motors, actuator and valve, up to three temperature sensors, all connected to one module C-HM-0308M

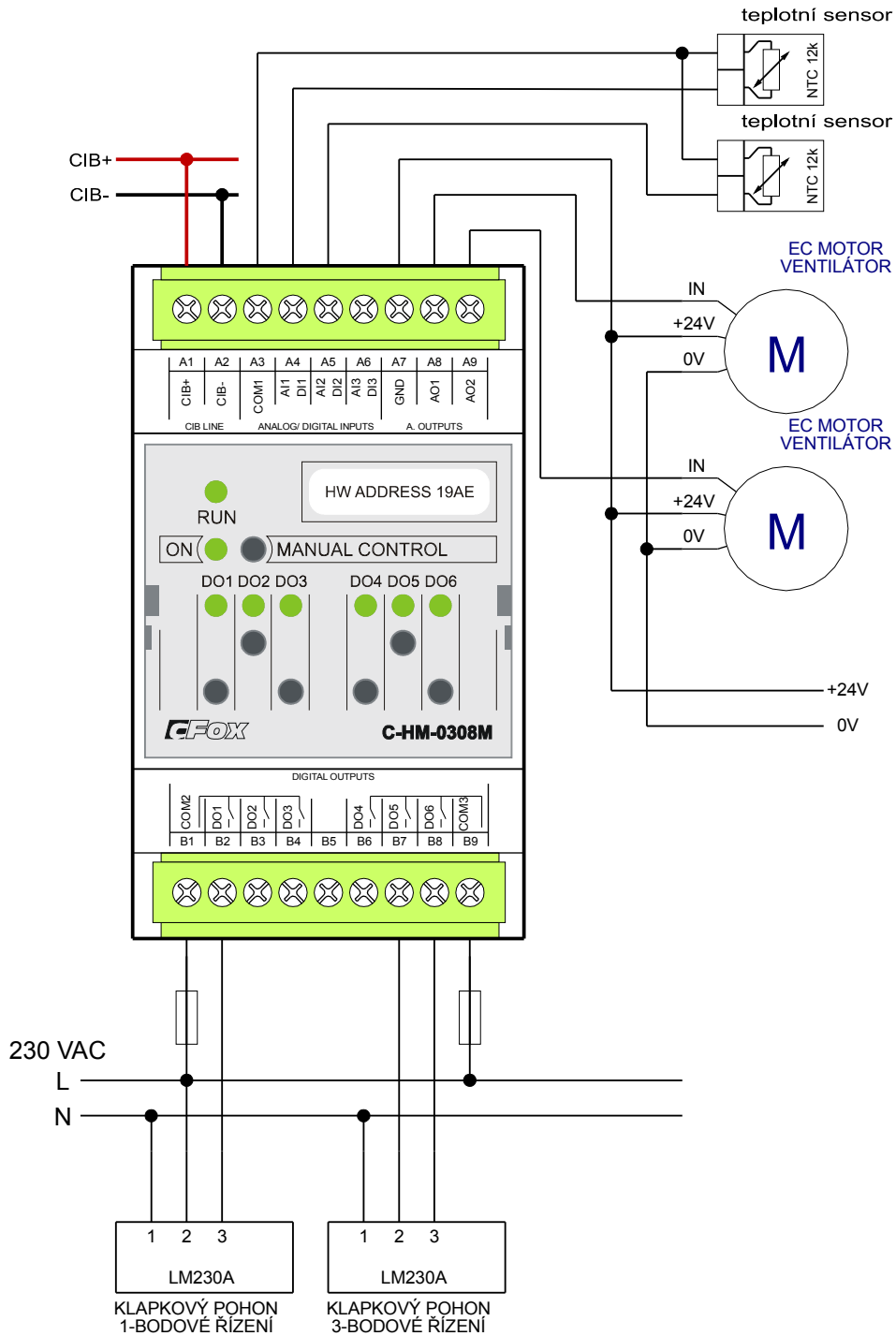

## 5.2 Heat recovery system – decentralized ventilation unit inVENTer

To power and control up to two independent inVENTer ventilation units the C-VT-0102B module was designed. The module is fully powered from the CIB bus. The maximum output power is 5W. During the operation of two fans. So the the module loads the CIB like about 5 normal CIB modules.

The module is equipped with an input for an external temperature sensor for interior or exterior temperature.

Two inVENTer units – the fans - are connected directly to module outlets A1 and A2, respectively B1 and B2. The order of wires is not so important . It can be corrected in the module configuration procedure.

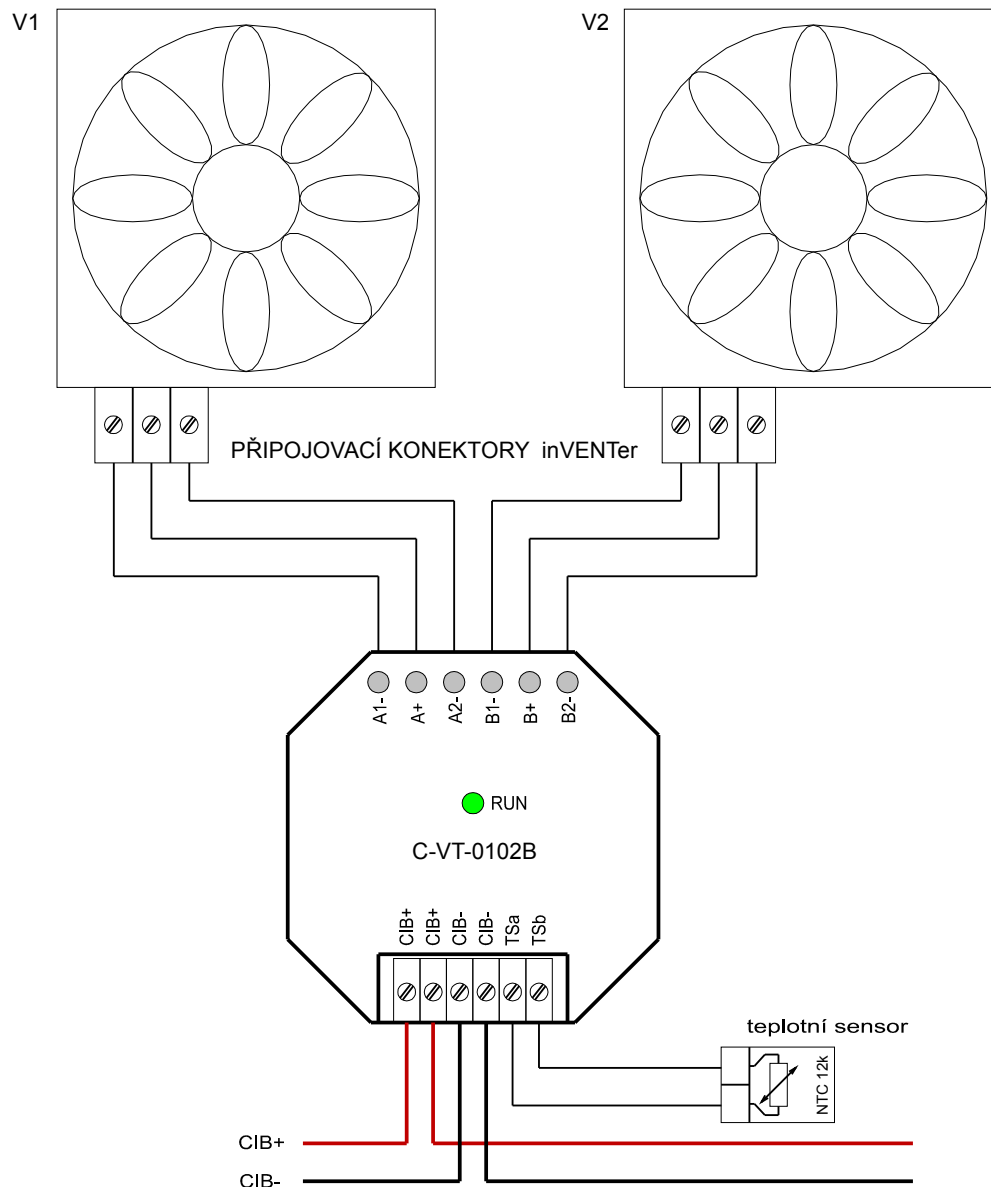

Fig. 5.2.1 Example of connections two fans of inVENTer system

### Notes:

1. As temperature sensor on TSa, TSb terminals can be used: NTC 12k, NTC thermistors can have max. 160kOhm.
2. Fans of inVENTer units are to be connected directly on the wire outlets by max. 15m long wires
3. Module C-VT-0102B has the consumption 5W at max. speed of both fans

## 6 Lighting

Light source classification:

**LED stripes** and LED powered by low voltage typically 12VDC, 24VDC.

Light intensity is controlled by the voltage. See module [C-DM-0006M-ULED](#). Recommended way how to switch the LED power supplies is in the [chapter 6.1.1](#).

**Power LED** supplied by the rated current (typically 350, 500, 700, 1000 mA).

Dimmable by controlled current source, see the [C-DM-0006-ILED](#). The recommended method of switching sources for LED is shown in [chap. 6.1.1](#).

**Compact LED light** (LED bulb incorrectly).

Replace incandescent light bulbs, available with standard light bulbs screw-threads, 230VAC, usually can not be dimmed.

**Tube LED light** (LED lamp incorrectly)

Replacement of fluorescent tube, for 230 VAC, usually can not be dimmed.

### Incandescent bulbs

Based on light emitting which is generated by heating the solid at high temperature. (Thank you, Mr. Edison!) The advantage is simple installation and maintenance, the disadvantage is low specific light power. Wattage of 25W incandescent bulb is about 9 lm / W. Disadvantage is also short average life about 1000 hours. They can be dimmed easily. In EU without perspective. (Thank you, Brusel!)

### Halogen bulbs

Halogen bulb is filled usually by the mixture of nitrogen and argon, krypton or xenon and compounds of them. They are made for 230 VAC as well as miniature and special types for low voltage, usually 12 VAC/DC. They have higher efficiency than conventional bulbs, but they are expensive and have very little resistance to the surge. They can be dimmed easily.

### Fluorescent lamps (low pressure lamps)

They are a popular source of light. Approximately 21% of energy supplied is converted into light in fluorescent lamps. Their life cycle is 8-12 000 hours. For dimming there are used dimmable electronic ballasts. Ballasts are controlled by analog signal 0 (1) ÷ 10V or by DALI interface. For example - see the [C-DL-0012S](#).

### Compact fluorescent lamps

Sometimes called "energy-saving lamps" they are light sources that combine the features of fluorescent lamps and the appearance of incandescent bulbs. Compact fluorescent light belongs to the low-pressure mercury discharge sources and is designed as a fluorescent tube with electronic ballast integrated in the socket. Specific performance ranges from 50 to 100 lm / W. Usually they cannot be dimmed. For dimming purposes special types are produced explicitly labeled as "dimmable". The brightness is usually dimmed as other ordinary incandescent bulbs.

### High pressure discharge lamps

(mercury lamps or sodium lamps with a very high pressure, xenon lamps). This light sources are typically used for street lighting and similar purposes. High-pressure discharge lamps are usually not dimmed.

## 6.1 Switching - LED lights

### 6.1.1 Switching LED power supplies at the 230V side

Most of switching power supply designed to power LEDs have a negative characteristic - a big initial current peak when connected to mains voltage 230VAC. Therefore, control of switching power supplies is not recommended to use any module or any relay which is not specifically designed for high initial currents.

Common used power supply MW: LPV-35-12 (for 35W, 12VDC) can take shortly current up to 60A while connected on the mains 230VAC. Cold start according to the manufacturer's data sheet. For switching such power sources the C-OR-0008M module is highly recommended:

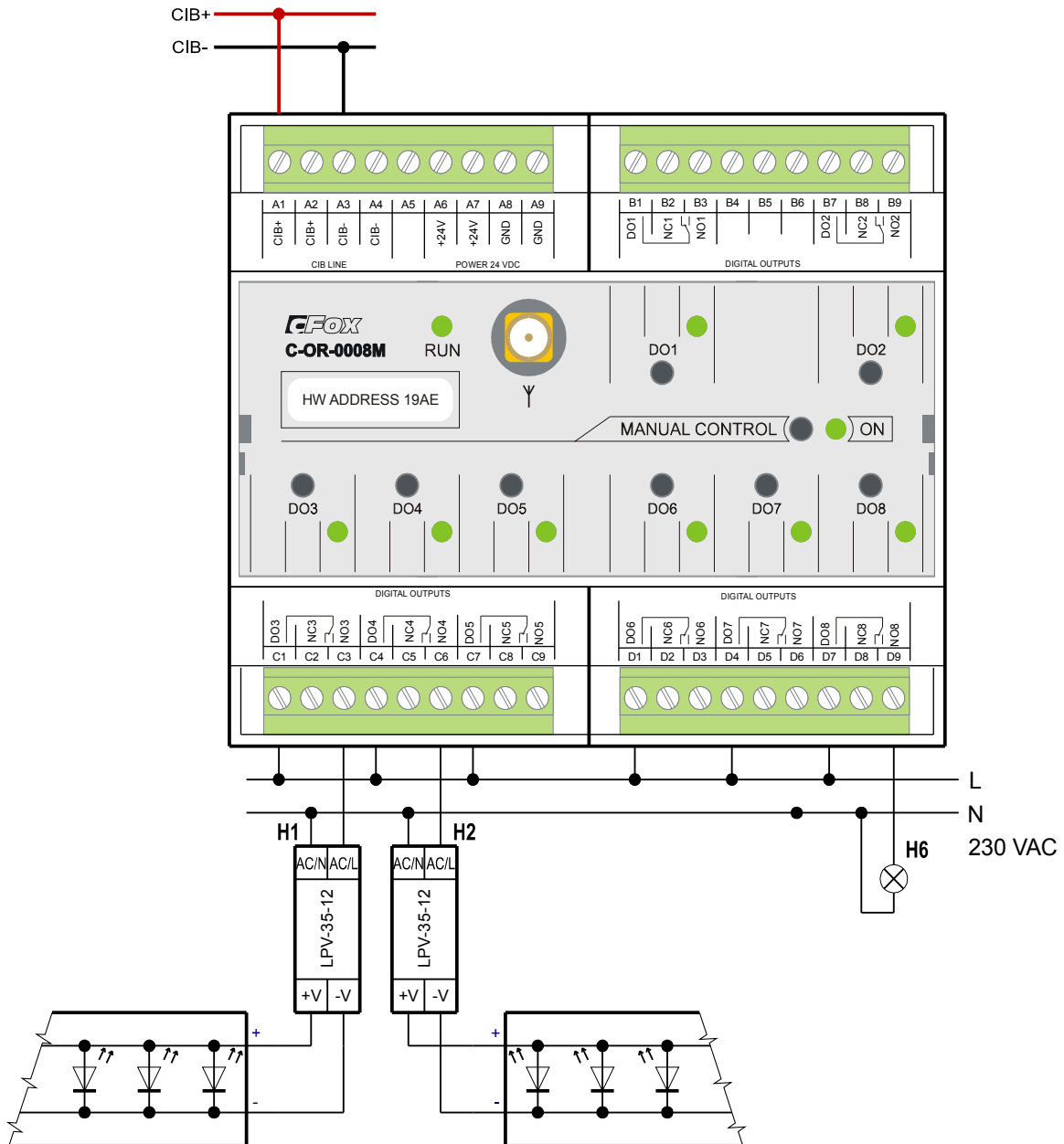

Fig. 6.1.1.1 Example of switching power supplies for LED by C-OR-0008M module. If you want to use a power supplies 230VAC/12 VDC to powering multiple LED stripes and you require separate switching of individual stripes, and even shut down the source (to permanently cut the current at light off), it is possible utilize advantage of the C-HM-1113M or C-HM-1121M. To switch power supply at 230VAC side you can use 16A output DO11 at C-HM-1113M. This output is designed for



switching current up to 80A. The other relays with lower current capability of 5A, can be used for individual switching of LED. See Fig.

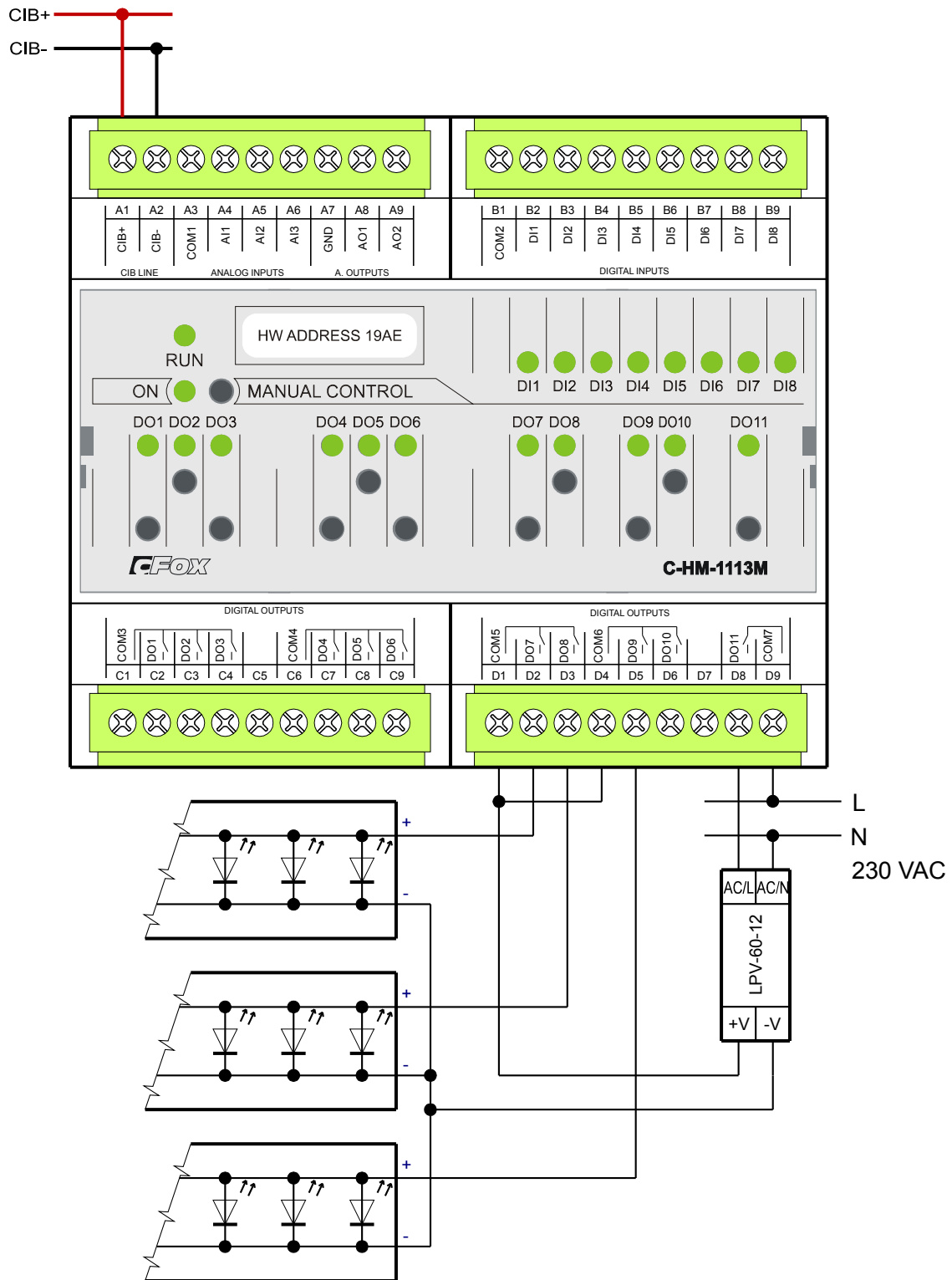

Fig. 6.1.1.2 Example of switching LED stripes by C-HM-1113M module.

## 6.2 Switching - Incandescent bulbs - 230 VAC or 12 VDC

For switching incandescent light bulbs we can use any relays of Foxtrot system. E.g. Relay output module C-HM-0308 is equipped with relay contacts 5A, with 3A continuous current, so we can switch on each output up to 600W bulbs. For higher performance you can use 16A relays on C-OR-0008M or on C-HM-1113M and C-HM-1121M modules. Also some wireless modules like R-OR-0001B includes 16A relays.

Transformers for low voltage halogen lamps must be switched in the same way as above. To switch electronic transformers 16A relays are recommended.

To switch fluorescent lamps (both conventional and compact) with internal or external ballast 16A relays are recommended as well.

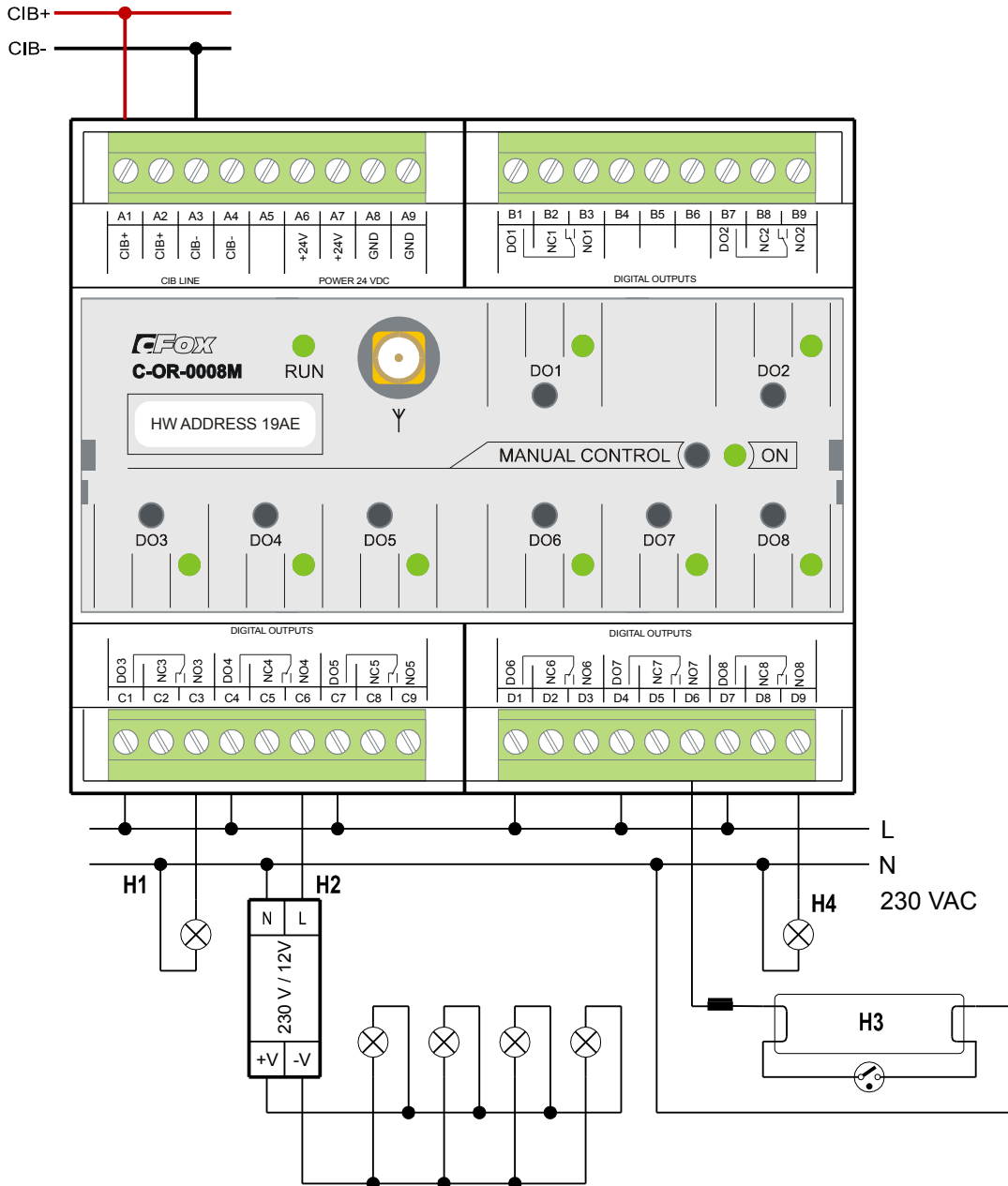

Fig. 6.2.1 Example of switching incandescent and fluorescent lamps by C-OR-0008M module.

### 6.3 Dimming - LED stripes, controlled by 12V or 24V voltage.

To control brightness of LED stripes with nominal voltage of 12V or 24V DC can be performed by C-DM-0006M-ULED, which can control the voltage proportionally (0-100%).

Max. current per output is 4A, maximum supply current of common terminal (terminals A6, A7) is 24A.

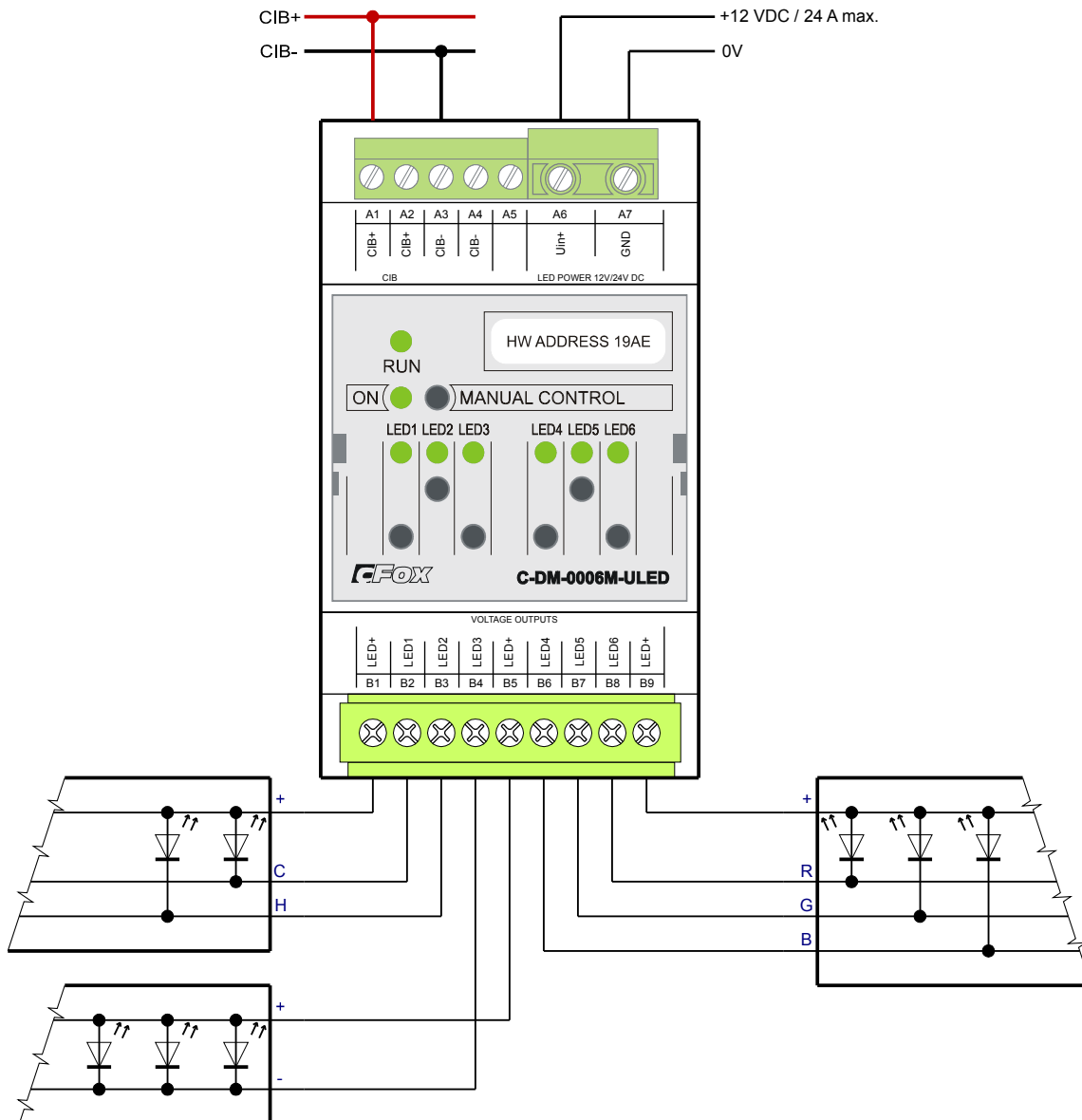

Fig. 6.3.1 Example of connecting the multichannel LED stripes dimmer C-DM-0006M-ULED.

#### Notes:

- 1) Max. current of each output (LED1 .. LED6) is 4A.
- 2) Current of each common output terminal LED+(B1, B5, B9 terminals) is 16A. So it is not allowed to connect all LED stripes to the same common terminal e.g. B1, when we want to use maximum power from all outputs.
- 3) Each module has to be powered from individual power source 12V or 24V/24 A max.
- 4) The negative terminals of CIB (A3, A4) has galvanic connection with the negative terminal of LED (A7)

## 6.4 Dimming - LED chips, current supply for 150mA 350 mA, 500 mA, 700 mA

To control brightness of power LED chips by the current the C-DM-0006M-ILED can be used. It can independently control up to 6 output for 6 power LED with following rated currents: 150mA, 350 mA, 500 mA, 700 mA. Power supply for LED can vary from 4,5 up to 48 VDC. The power supply is the same for all LED controlled by this module.

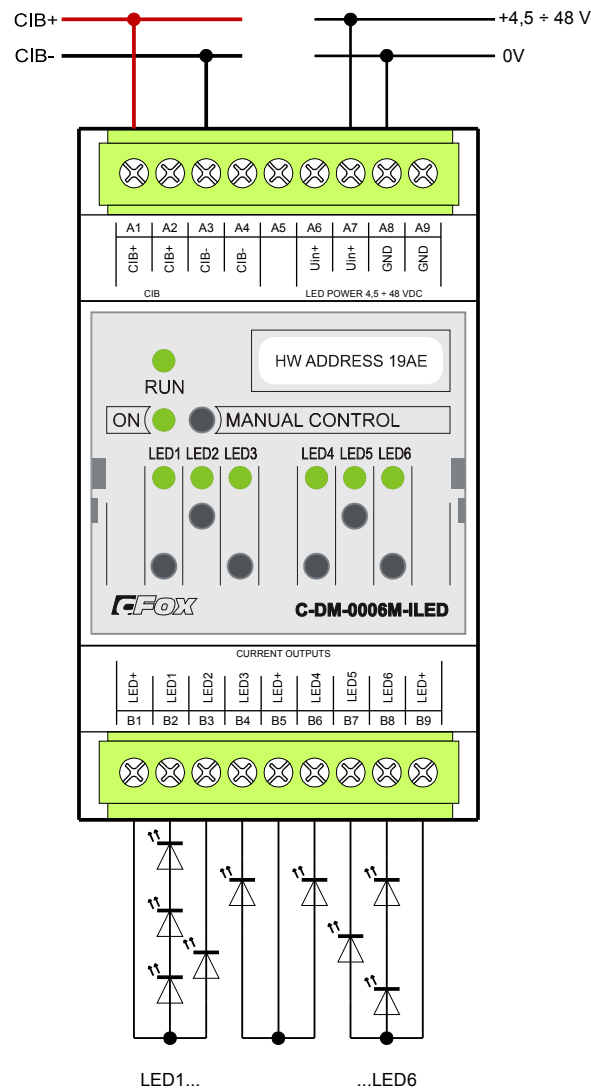

Fig. 6.4.1 Example of connecting the LED chips to the multichannel LED dimmer C-DM-0006M-ILED with controlled current outputs

### Notes:

- 1) max current per output (LED1 up to LED6) is configurable for 350 mA, 500 mA, 700 mA, 1000 mA. Output current per output is always controllable in the range from 0 to max current.
- 2) Supply voltage for the LED is connected to the doubled terminals U<sub>in</sub> + and GND. The power source must have an output voltage in the range of 4.5 V to 48 V.
- 3) It is possible to control the current of more LED in series. The supply voltage (max. 48V) should be used.
- 4) Negative terminal of CIB (A3, A4) has galvanic connection with the negative terminal of power supply (A8, A9). It is recommended to supply more C-DM-0006M modules from one power supply only in case, they are side by side in order to use wires as short as possible.

## 6.5 Dimming – DALI interface

To control lighting devices over DALI protocol (typically fluorescent ballasts, etc. ..) the protocol converter CIB - DALI C-DL-0012S was designed. It is ready to control devices with DALI protocol according to specifications: NEMA Standards Publication 243-2004 Digital Addressable Lighting Interface (DALI) Control Devices Protocol PART 2-2004.

CIB and DALI signals are connected via terminated color cables. Supplying of module comes from the CIB. The module does not provide galvanic isolation of CIB and DALI.

Module C-DL-0012S allows to control independently up to 12 DALI ballasts on one DALI bus.

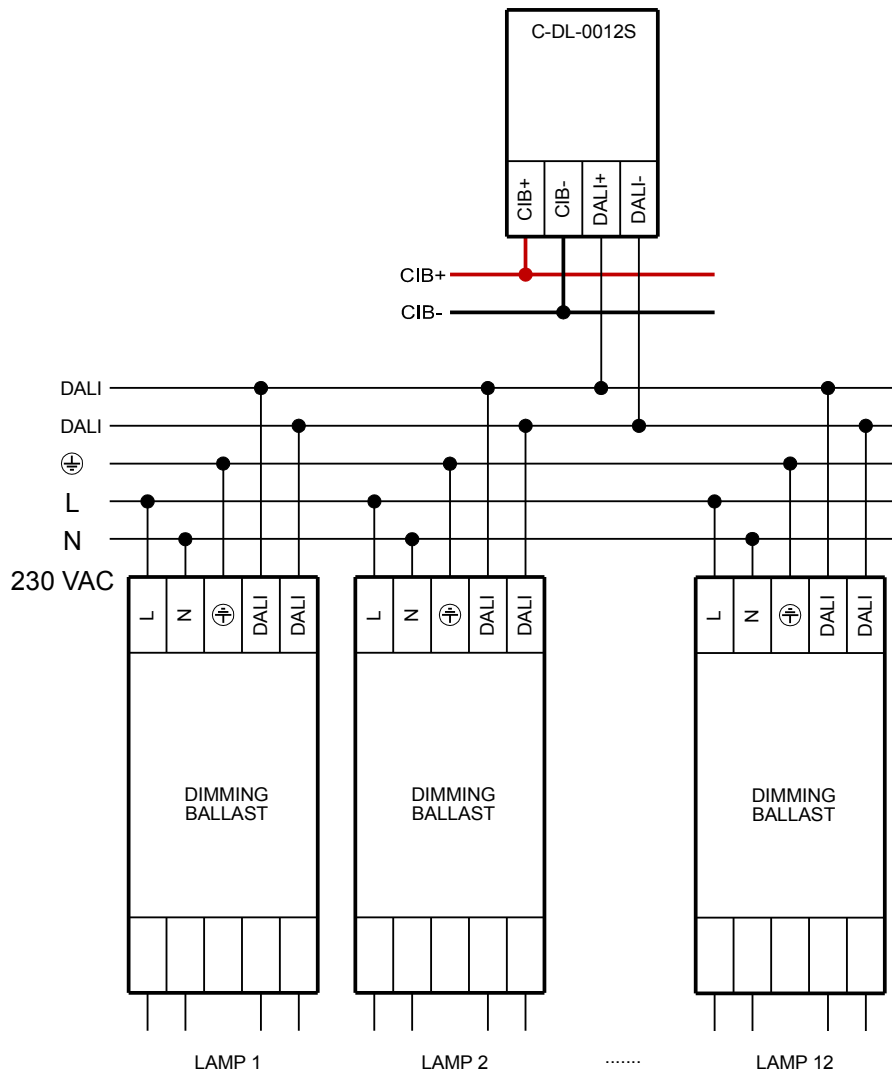

Fig. 6.5.1 Example of C-DL-0012S connection to control DALI dimming ballasts.

### Notes:

- 1) For DALI standard cable with  $5 \times 1.5 \text{ mm}^2$  should be used together with power cable of 230VAC. The total cable length is up to 300m. Topology of DALI can be linear, tree or star.
- 2) DALI bus is not polarized so you can swap the two signal conductors of the DALI slave elements. The bus need not to be terminated by any element. DALI bus has galvanic isolation from the operating voltage 230VAC (meets SELV requirements).

### 6.6 Dimming - Fluorescent lights and compact fluorescent lamps

To control the electronic ballasts of fluorescent lights by 0-10V or 1-10V voltage the C-IR-0202S module can be used. The module has one relay output for switching on/off the power to avoid the consumption during idle period and has analog output to control the brightness. It can be fitted directly into the lights or wired in flush box. Any other module with both relay and analog output can be used for the same purpose as well. E.g. module C-HM-xxxxM for DIN rail).

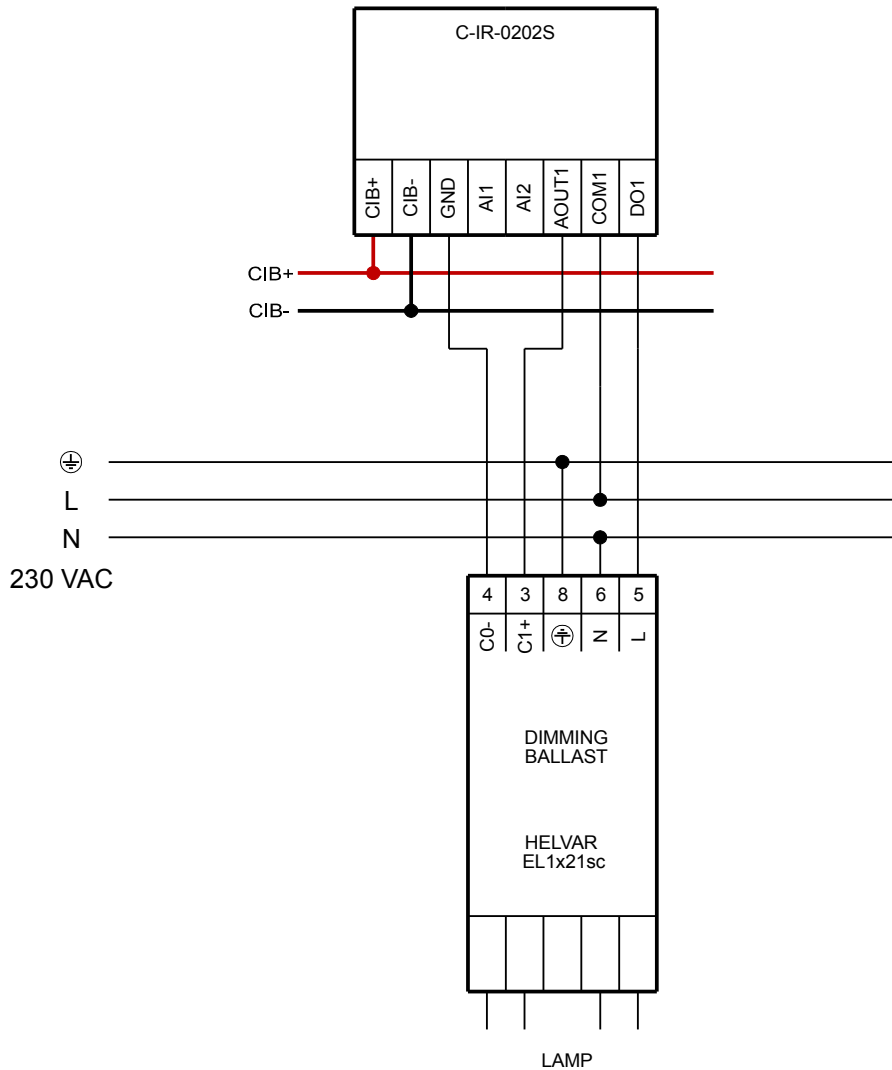

Fig. 6.6.1 Example of 1-10V ballast controlled by C-IR-0202S

## 6.7 Dimming – Low voltage lights with inductive and electronic transformers

LM2-11B - dimmer for flush box or DA2-22M double dimmer for DIN rail can be used for dimming low voltage lamps powered by inductive or electronic transformers. Both they allow to switching and to dim RLC loads (resistive, inductive and capacitive). They support auto-detection of the load type

Note: It is not permitted simultaneous connection of inductive loads and capacitive load. It is also necessary to protect the L input by the fuse with F characteristics and it must be rated according to the connected load.

Dimmers LM2-11B and DA2-22M also have digital inputs 230 V AC, which can be used for local control. Following figure shows connection of inputs and outputs dimmer DA2-22M.

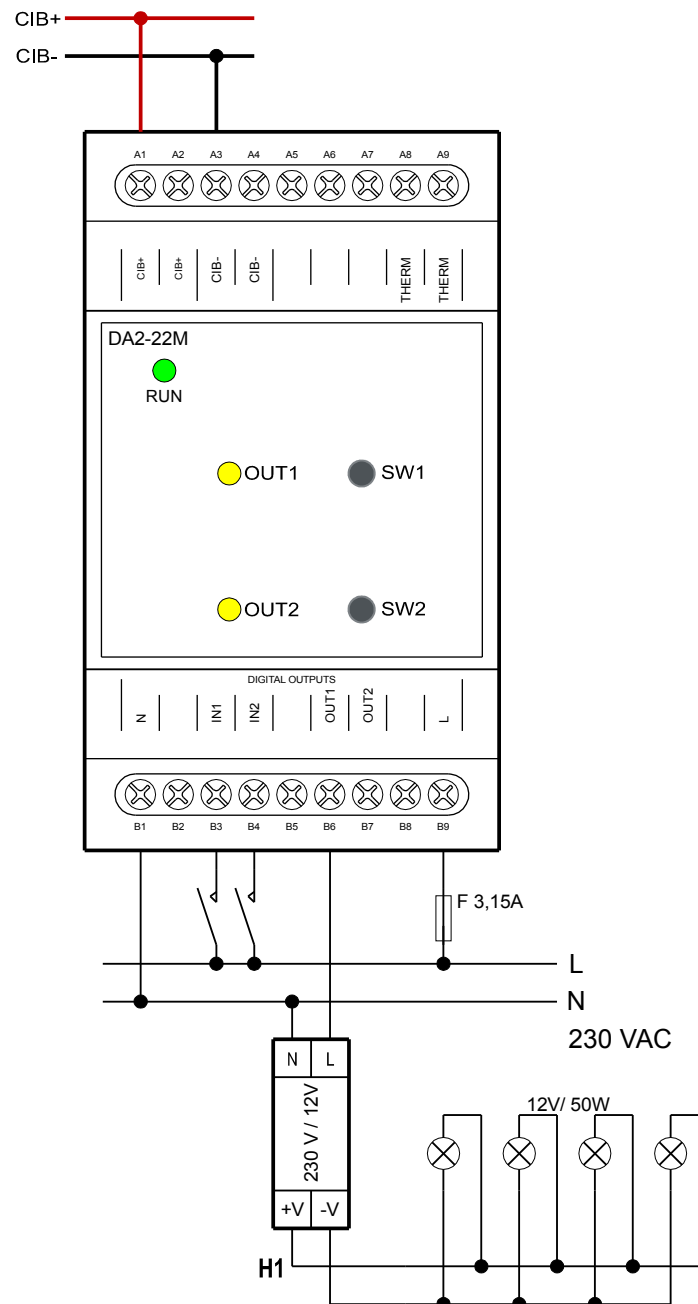

Fig. 6.7.1 Example of DA2-22M connection

## 6.8 Dimming – Incandescent lamps

LM2-11B - dimmer for flush box or DA2-22M double dimmer for DIN rail can be used for dimming 230VAC incandescent lamps. Both they allow switching and dimming of RLC loads (resistive, inductive and capacitive). They support auto-detection of the load.

Note: It is not permitted simultaneous connection of inductive loads and capacitive load. It is also necessary to protect the L input by the fuse with F characteristics and it must be rated according to the connected load.

Dimmers LM2-11B and DA2-22M also have digital inputs 230 V AC, which can be used for local control. Following figure shows connection of inputs and outputs dimmer DA2-22M.

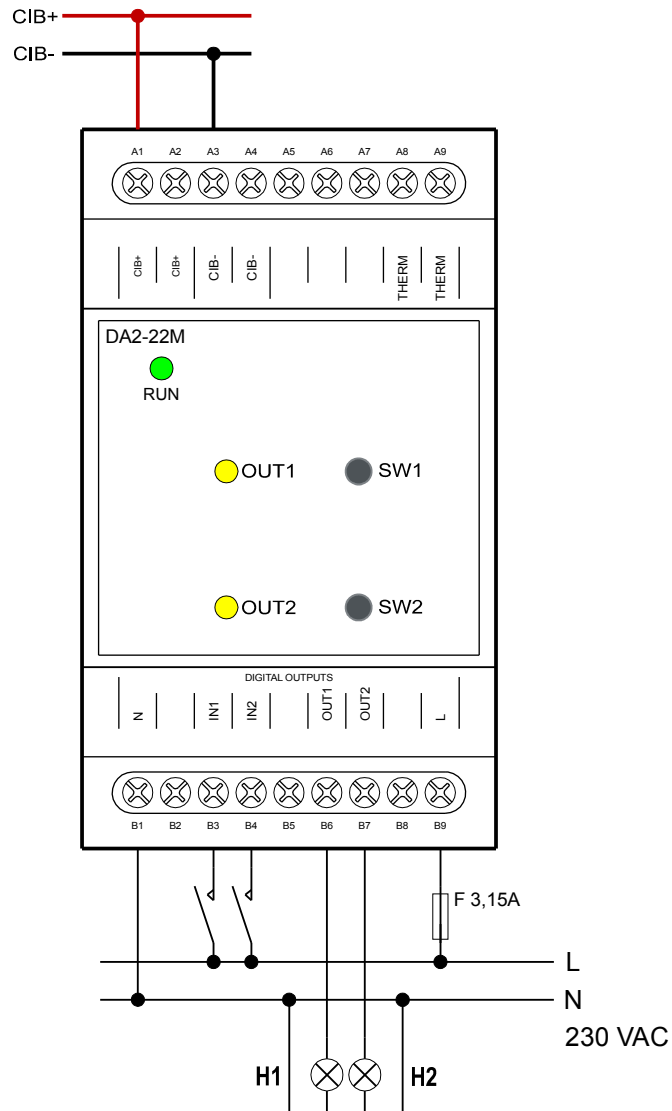

Fig. 6.8.1 Direct connection of dimmed incandescent lamps to DA2-22M module



## 6.9 Dimming – DMX512 control

DMX512 is a serial protocol to control devices such as light dimmers, lasers and other special effects using digital interface. The protocol is maintained by ESTA (Entertainment Services and Technology Association) since 1998. Multidrop topology of the bus contains one control station - master and more controlled slave devices. DMX512 uses the RS485 interface, so the topology of the bus is line and the last station has to be terminated by 120  $\Omega$  terminal.

DMX512 master can be realized only within the Foxtrot basic module using sub-modules MR-0105, MR or MR-0106 or MR-0115 inserted at SCH2 optional slot. These sub-modules contain combination of 3 serial interfaces RS485 and RS232 addressed as CH2, CH3, CH4. One or two DMX512 masters can run only on the communication channels CH3 and CH4 where the interface RS485 at specific bit rate 250 kBd can be realized.

To control lighting over DMX512 there is library of supporting functional blocks in the Mosaic programming tool.

## 7 Shutters, blinds, motors

Motors for shutters, blinds and similar devices are typically AC asynchronous motors with reversing of coils. Typical consumption of such motors is between 60 and 150 VA. It is necessary to avoid simultaneous connection of control voltage at both up and down input terminals. Most likely it will damage the engine. For this purpose any relays pair is suitable. Due to the exclusion of simultaneous switch on it is preferable to use relays with changeover contacts which allows hardwired exclusion of simultaneous appearance of control voltage on both relay outputs (see Chap. 7.1).

For interior shutters also small motors 12 VDC or 24 VDC are used. In this case the direction is controlled by changing the polarity of supply voltage (see Chap. 7.2.)

Custom logic control (teaching the end position, time of running, positioning of blinds) must be included in the application program according to specific engines and controlled shading elements.

### 7.1 Control of 230V motors for outdoor shutters, awnings, etc.

To control motors with reversing 230VAC coil (similarly to the 3-position actuators for valves and dampers) and to avoid the simultaneous presence of control voltage on both relay outputs, we recommend external connecting of relay contacts NC1 and DO2 as on picture below.

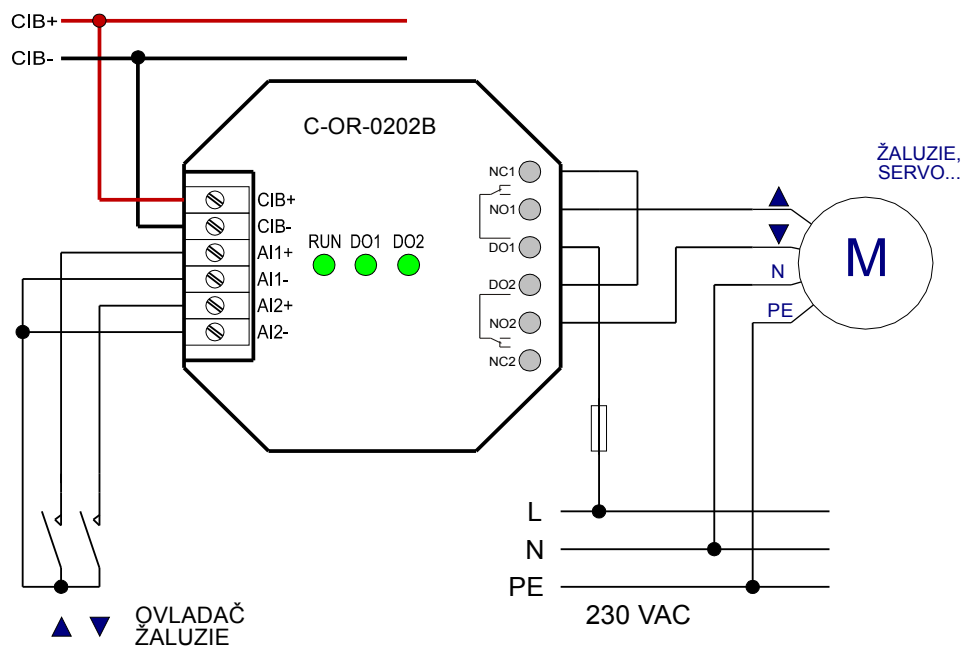

Fig. 7.1.1 Example of shutter motor control by C-OR-0202B module

#### Notes:

- 1) Relay outputs with mutual interlocking of both outputs: when DO1 switches on, the motor goes up, DO2 switches on – the motor goes down. If both DO1 and DO2 switch on, the motor stops.
- 2) Relay contacts on C-OR-0202B allows 80A of peak current so they can overcome short current peaks during closing and opening of contacts.
- 3) Due to power of motors for shading elements the control and power cable with cross-section section 1.5 mm<sup>2</sup> fully complies
- 4) Two universal inputs (AI1, AI2) can be used either for buttons for manual control.
- 5) It is possible to place the module into deep flush box or into flush box with side space or just under the mechanical wall switch.

C-OR-0008M module can be used to control the shutters from the central cabinet:

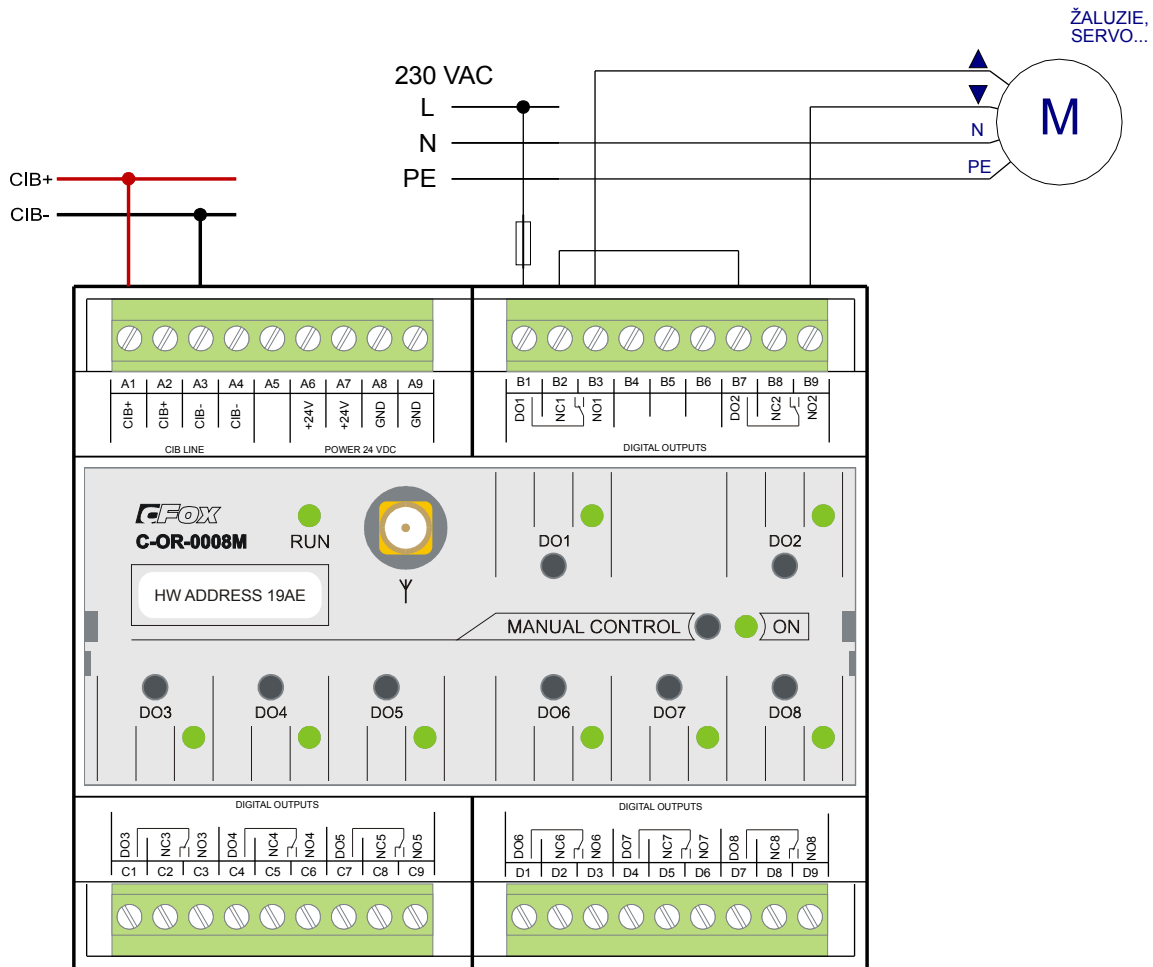

Fig. 7.1.2 Example of shutter motor controlled by C-OR-0008M

Notes:

- 1) Relay outputs with mutual interlocking of both outputs: when DO1 switches on, the motor goes up, DO2 switches on – the motor goes down. If both DO1 and DO2 switch on, the motor stops.
- 2) Relay contacts on C-OR-0008B allows 80A of peak current so they can overcome short current peaks during closing and opening of contacts.
- 3) Due to power of motors for shading elements the control and power cable with cross-section section 1.5 mm<sup>2</sup> fully complies

## 7.2 Control of DC motors for shutters and blinds

To control the DC motors with reversing the polarity by switching power supply (internal motors for blinds, etc.) we recommend the relay outputs with changeover contact, such as C-OR-0202B.

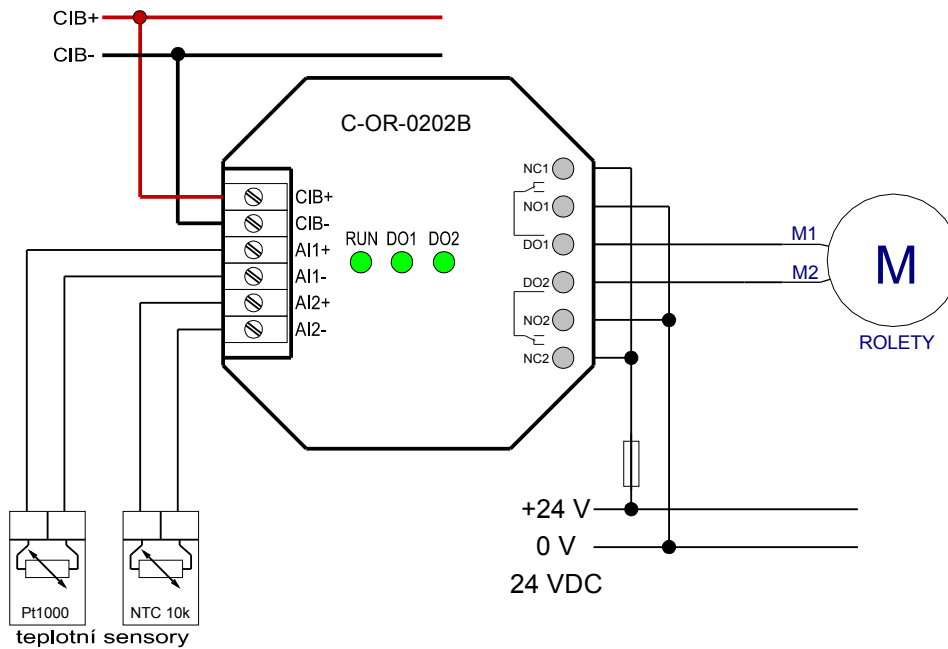

Fig. 7.2.1 Example of connection DC motor by C-OR-0202B module

### Notes:

- 1) Power supply for the motors and the relevant protection must follow the recommendations of the shutters manufacturer.
- 2) An external temperature sensor and/or the window contact can be connected to general purpose inputs A1, A2

## 8 Security Systems, Fire Alarm Systems

### 8.1 Security sensors (PIR, ...)

Security sensors (PIR – motion detectors, glass break sensors, etc.) available on the market are equipped with two relay outputs – alarm and tamper. They are suitable for connection to inputs of CFox or RFox modules.

Connecting and evaluation in the Foxtrot system can be done by several ways - see Chap. 8.1.1.

In chapter 8.1.2 we present a basic example of the dual balanced PIR sensor. For 12 VDC power supply the PS2-60/27 power supply is recommended. Its 12V voltage level stay active during power failure running from the backup battery.

#### 8.1.1 Configuration of inputs for security sensors

(based on documents [7]. More detailed information can be found there):

##### NC contact - Normally Closed

Such connection is usually used for connecting of detectors, where is low probability of the loop sabotage. You can find such simple connecting in home security and alarm systems frequently. Basically, it is not wrong connection. But it cannot exclude detection of the detector failure or whole group of detectors gfailure in case of short circuit in wiring or on terminal block. Therefore, it is more advisable to use balanced loop.

##### Balanced loop

It can be used mostly where more detectors are wired in one loop. So the contacts are wired in series. Wiring is simple and transparent. The disadvantage of this case are more detectors in the series so the exact place of activated element cannot be determined exactly. Contacts TAMPER and ALARM are always normally closed, so NC closed contact represents the idle state.

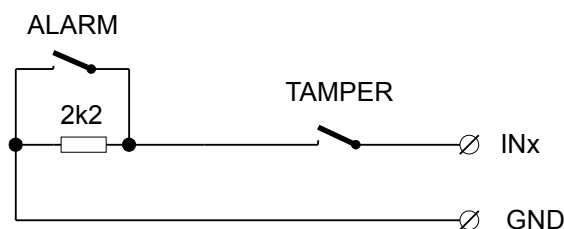

Resistance of the loop:

Idle status	2k2
Activation	0 or $\infty$

##### Double-balanced loop

Each security detector usually gives two piece of information. ALARM - Activation like motion, open the door....and TAMPER - disruption of the cover - sabotage.

Using two values of resistance idle state and activation can be indicated. Idle state is determined by baseline resistance, activation is determined by doubling this value. Short circuit or open loop is seen as loop sabotage or opening of the cover. There is tolerance range of resistance value about 10% not to cause the wrong alarm due to resistance fluctuations by temperature.

If the security panel has sufficient amount of wire loops, it is advantage to connect each detector to a separate loop. The loop is then able to indicate both the activation as well as sabotage of the loop or the detector. Connecting more detectors to a double balanced loop the wiring is more complicated. Since TAMPER and ALARM contacts are always normally closed the closed contact represents the idle state.

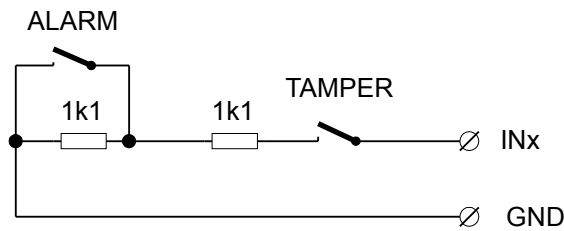

Resistance of the loop:

Idle state	1k1
Activation	2k2
Sabotage	0 or $\infty$

### 8.1.2 Connecting of security sensor in double balanced loop

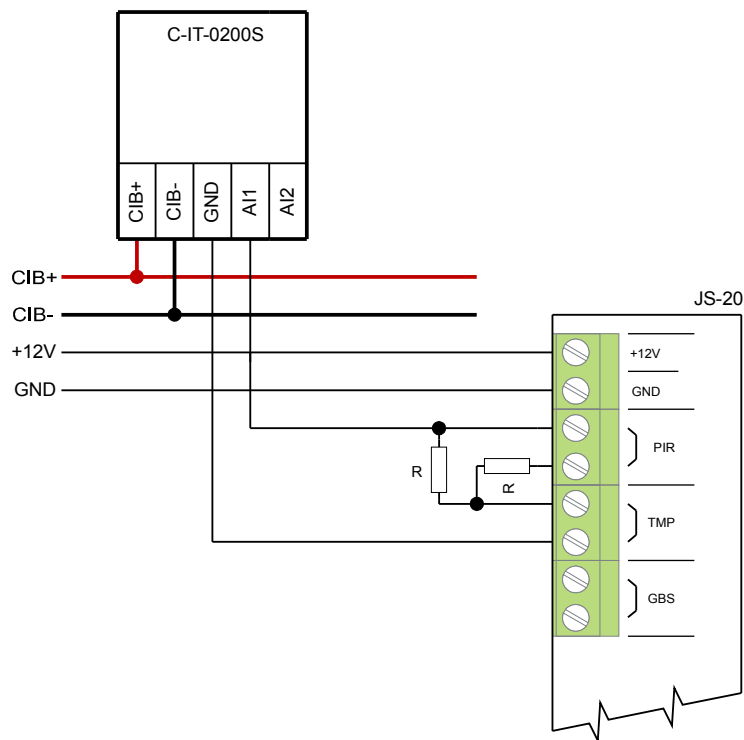

Fig. 8.1.2.1 Example of security sensor (here JS-20 by Jablotron) sensing by C-IT-0200S module

If the certified security system is required (due to conditions of insurance companies, etc.), you have to choose the security systems (e.g. Paradox) on the market equipped with a communication interface to be connected to the Foxtrot system. In such case you can involve such security system into the management of the house and reuse the basic information for security purposes also during "unlock" period. E.g. for lighting control and presence simulation, attenuation of heating, shutting down socket circuits etc.

## **8.2 Fire alarm systems – wiring of detectors**

TBD

## 9 User interfaces - Communication with the user

### 9.1 Wall switches - flush mounted, light control, shutters control, etc.

#### 9.1.1 Wall switches with CIB

To control lighting, blinds, ventilation and similar applications you can use C-WS-0200R with one gang and 2 buttons – one on top one on bottom and/or C-WS-0400R with two gangs and 4 buttons. Both types of drivers are made in the design of ABB Time and both they enable to attach up to two temperature sensors:

- Indoor temperature with 12k NTC sensor available also in ABB's Time design
- Floor temperature with sensor fixed on the cable.

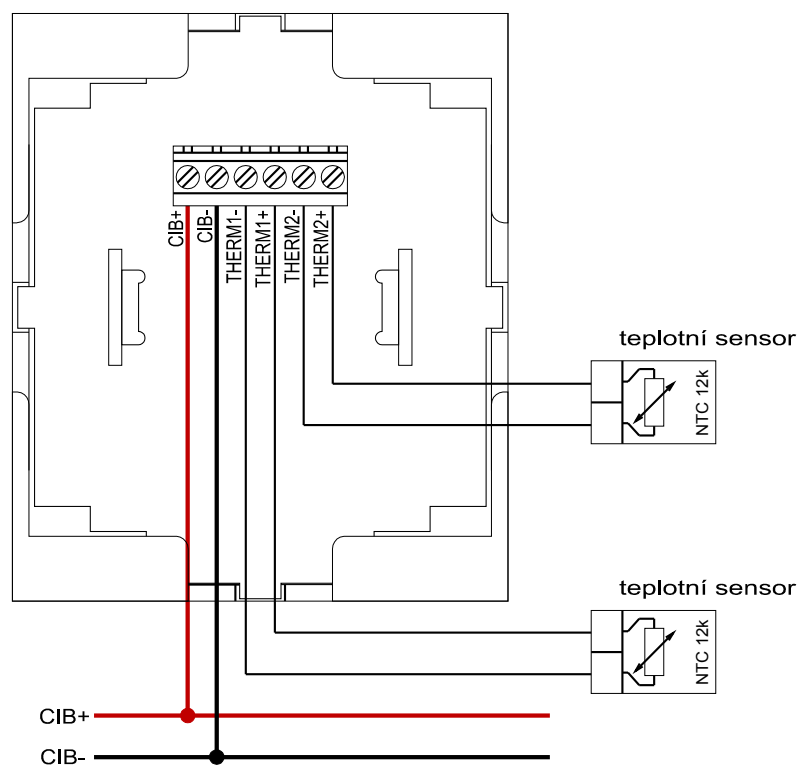

Fig. 1 Example of connecting C-WS-0200R and C-WS-0400R

#### Notes:

- 1) Temperature sensors must be 12k NTC type or other NTC with resistance up to 100kOhm, the length of cable can be up to tens of meters - typical cable for floor sensor is SYKFY or similar with 1x 2 wires and with diameter of at least 0.5 mm.
- 2) The module is designed as a standard installation element to the flush installation box (e.g. KU68)
- 3) Connection via fixed terminals of 3.5 mm pitch, for wires of max. 1.5 mm<sup>2</sup> cross-section



### 9.1.2 Wall switches coupled to CIB over flush mounted input module

In the case you need to use other interior design of wall switches you can choose practically any switch and couple it to the CIB over module with inputs for dry contact.

For the wall switch with one or two push-buttons C-IT-0200S module can be used, which can be placed directly into the flush box under the wall switch.

Also card holders usually used in hotels can be connected in the same way

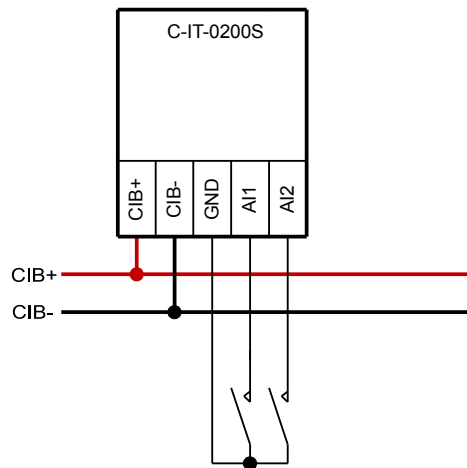

Fig. 9.1.2.1 Example of coupling two switches/buttons to CIB via C-IT-0200S module.

#### Notes:

- 1) All module outlets - CIB and inputs - are insulated wires about 100 mm length finished with sleeves which can inserted directly into the terminal of wall push-button.

### 9.1.3 Wall switches coupled to CIB over C-IT-0504S module

The built-in module C-IT-0504S can be used in a similar way as C-IT-0202S. It enables to connect up to four contacts and to measure the temperature sensor. It can drive up to 4 LED indicator at the same time.

Module has 5 configurable inputs. The configuration is not fully independent. Inputs can be configured in 2 groups. One of 4 inputs and the second of 1 input. They can be configured as analog inputs to read temperature sensors like Pt1000, or as binary inputs to read dry contacts or balanced inputs. There are also 4 analog outputs 0-10V/max. 3MA to control LED indicators on wall switeches, to control ballasts, heating....

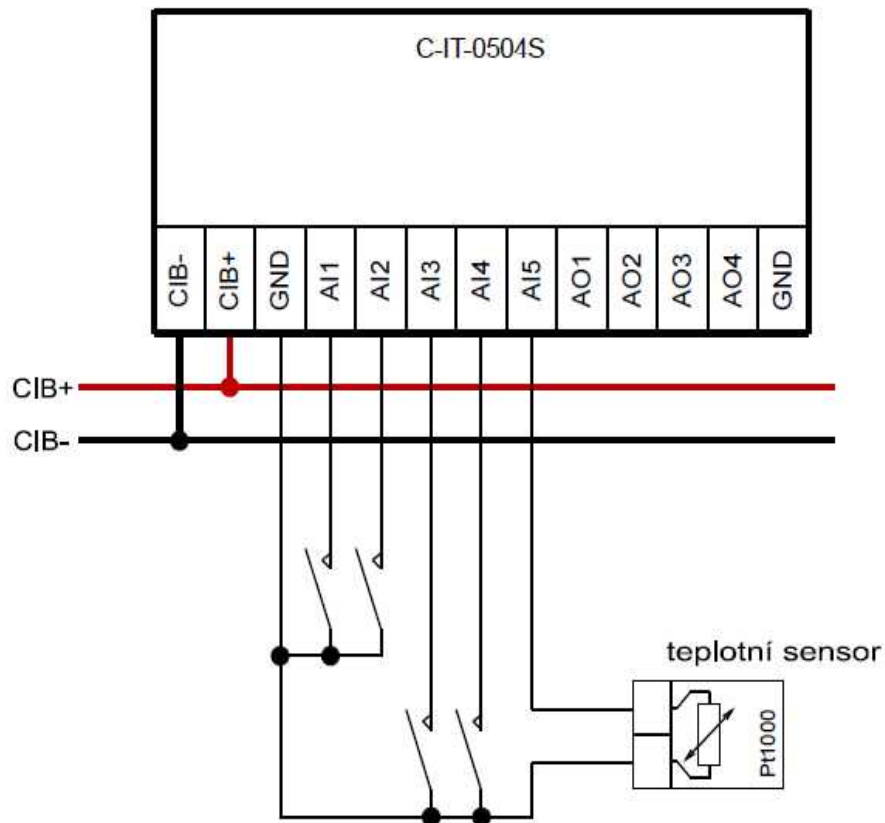

Fig. 9.1.3.1 Example of connection 4 push buttons and 1 temperature sensor to the C-IT-0504S module

#### Notes:

- 1) Example shows one configuration possibility: 4+1 (4 contacts, 1 analog input). Reverse combination i.e. 1 dry contact and 4 analog inputs is also possible.
- 2) Analog outputs can be used to control the 0-10V electronic ballasts.

### 9.1.4 Wall switch GIRA 2003 xx coupled to CIB over C-IT-0504S module

The wall switch GIRA 2001xx - part of the SYSTEM 55 design – has 2 dry contacts (24VAC/DC) and 2 LED (24VDC/1mA) under 1 gang. It can be connected to CIB over the C-IT-0504S module placed under the upper part. In such case this combination makes full CIB wall switch with LED indicators. Still we have another 3 inputs for room or floor temperature etc.

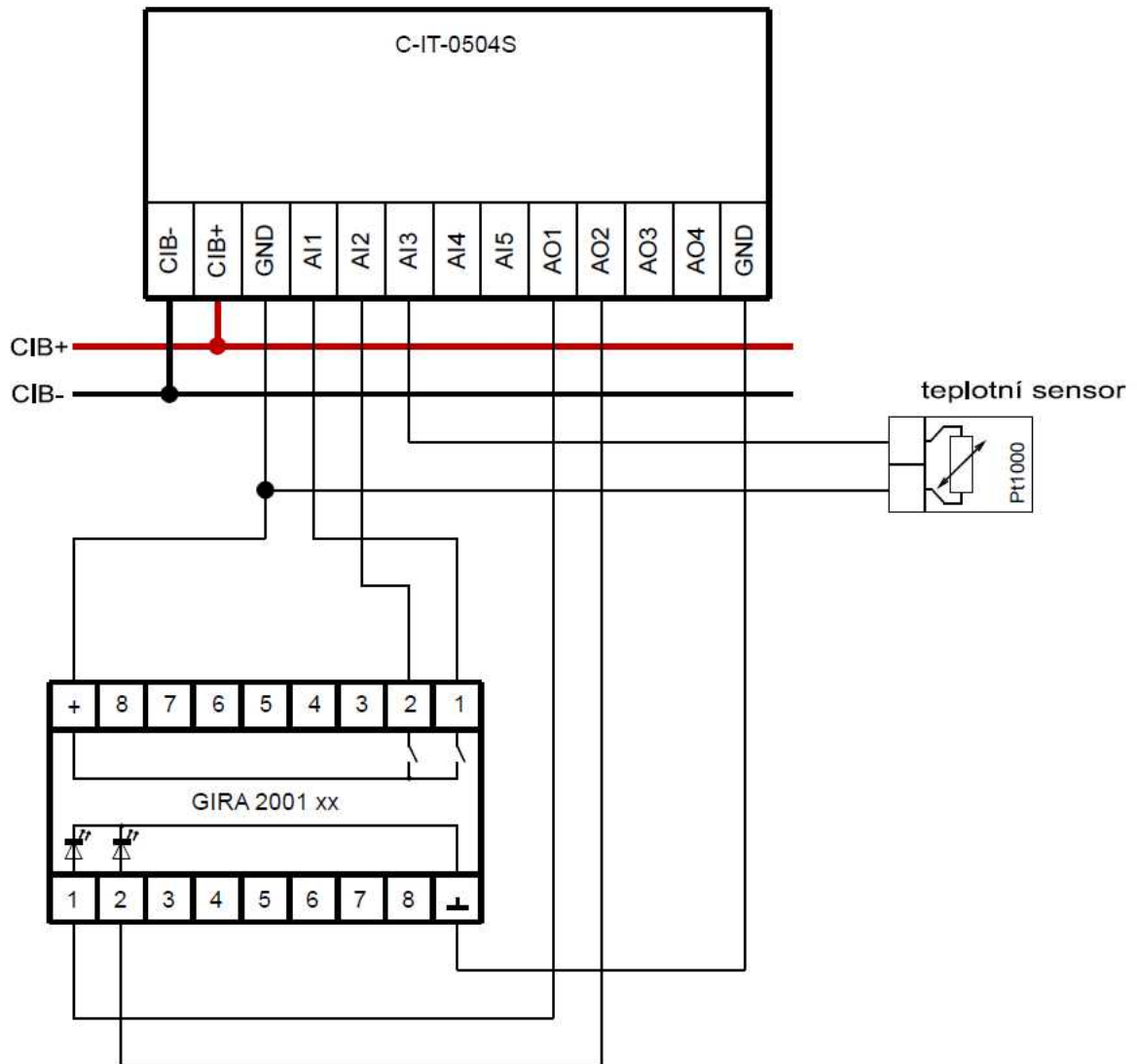

Fig. 9.1.4.1 Example of GIRA 2001xx wall switch connection to CIB via C-IT-0504S module together with temperature sensor.

#### Notes:

- 1) Analog outputs of C-IT-0504S can give max.10V/3mA. LED indicators of GIRA 2001xx driven by those analog outputs light normally. Analog outputs must be handled as digital. It means switched among 0% and 100%.
- 2) C-IT-0504S has 100mm wire outlets, which can be directly inserted into GIRA 2001xx connector. The colors of wires and other detail are in chapter:

### 9.1.5 Wall switches coupled to CIB over the DIN rail modules in the cabinet

In the case you need to use other interior design of wall switches/buttons you can choose practically any switch from any manufacturer and couple it to the CIB over any module with digital inputs for dry contacts.

For the installation where all modules will be placed in the central cabinet the C-HM-1113 and/or C-HM-1121 modules are suitable to connect dry contacts. They can be placed either in the main cabinet or in the auxiliary one in order to minimize number of cables in the house.

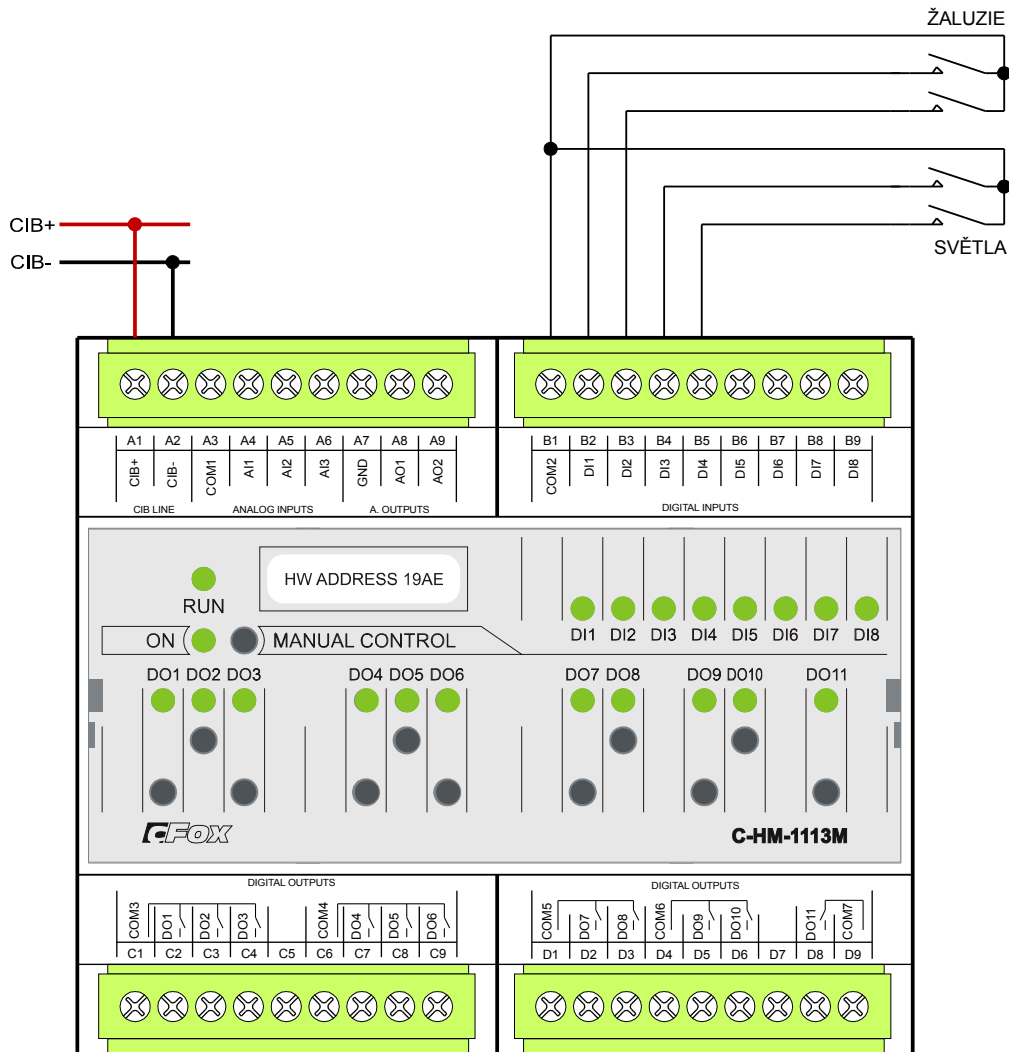

Fig. 9.1.5.1 Example of connection of dry contacts to C-HM-1113M

#### Notes:

- 1) Suitable cable for connecting contacts of wall switches are SYKFY, JY (St) Y, etc. Cable length can be up to about 30 m.
- 2) In case of multiple drivers in one place, the common multiwire cable can be used. The common cable can lead also the temperature sensor but the shielded cable is recommended in this case. E.g. Having multiple frame with push-buttons and a temperature sensor on the wall all of these signals can lead via common cable to cabinet, but shielded cable always should be used.
- 3) In case of large cable lengths and/or parallel installation along the low voltage installation, we recommend shielded cables (reducing the risk of false switching due to interference).

## 9.2 Wall displays for Heating control

### 9.2.1 Heating control module C-RC-0002R-design

The module consist of display for temperature, 3 buttons for setting of temperature and mode, LED indicator and embedded temperature sensor and terminal for external temperature sensor. Such modules are available in various designs compatible with wall switches.

The module consists of two parts. Built-in part contains electronics with the 4wire outlets to connect CIB and external temperature sensor. It contains the plug connector to insert the cable coming from the upper part. The upper part is a customized design cover installed on the wall with a display, buttons, LEDs and visible temperature sensor. Cable length is 70 mm with connector. External temperature sensor (NTC 12 kOhm to 100kOhm or NTC) is for example for measuring floor temperature.

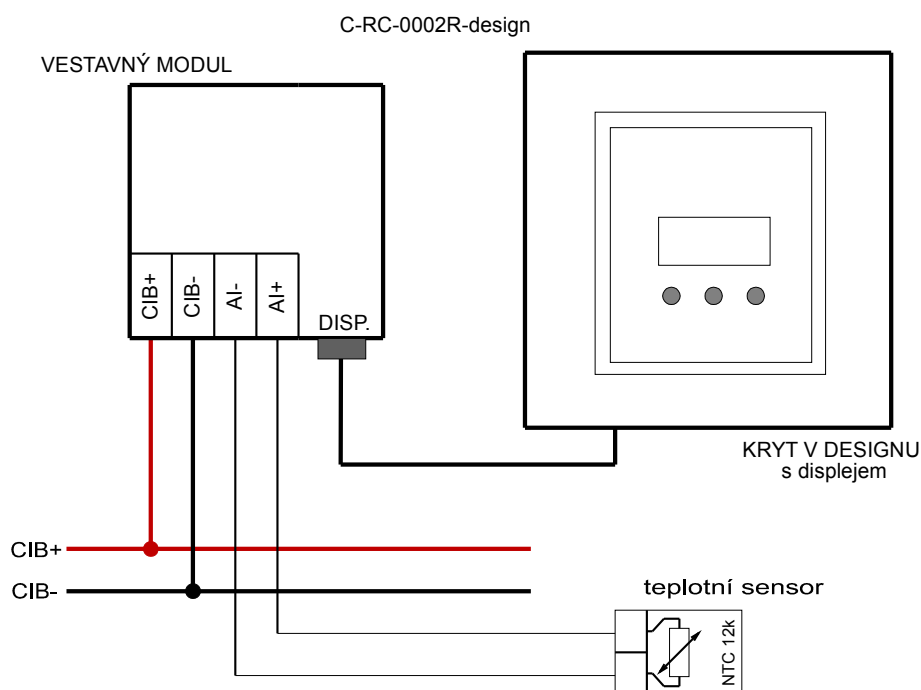

#### Notes:

- 1) External temperature sensor must be 12k NTC and other NTC with the resistance <math><100\text{k}\Omega</math>, the length of cable can be up to tens of meters - typical usage is floor sensor. Recommended cable is SYKFY 1x2 or similar with diameter at least 0.5 mm.
- 2) The module is designed as a small embedded module into a standard flush box (KU68), the module is completed by four wires of length about 10 cm (for CIB and for external temperature sensor) and plug connector into which the cable is inserted from the upper part of the module.
- 3) The upper part with the display buttons, LED and sensor is available in customized cover from different manufacturers

## 9.2.2 Heating control module RCM2-1

For comfortable, very simple and clear way to control heating - temperature correction, changing heating mode, manual fan speed control (stepped and proportional), to display outdoor temperature and time RCM2-1 module can be used

The module is equipped with an internal temperature sensor and allows to connect also an external temperature sensor NTC 12k. The module is to be fixed by 2 or 4 screws on the flush box 60 mm of diameter on the wall. The module is equipped with a monochromatic display with special symbols.

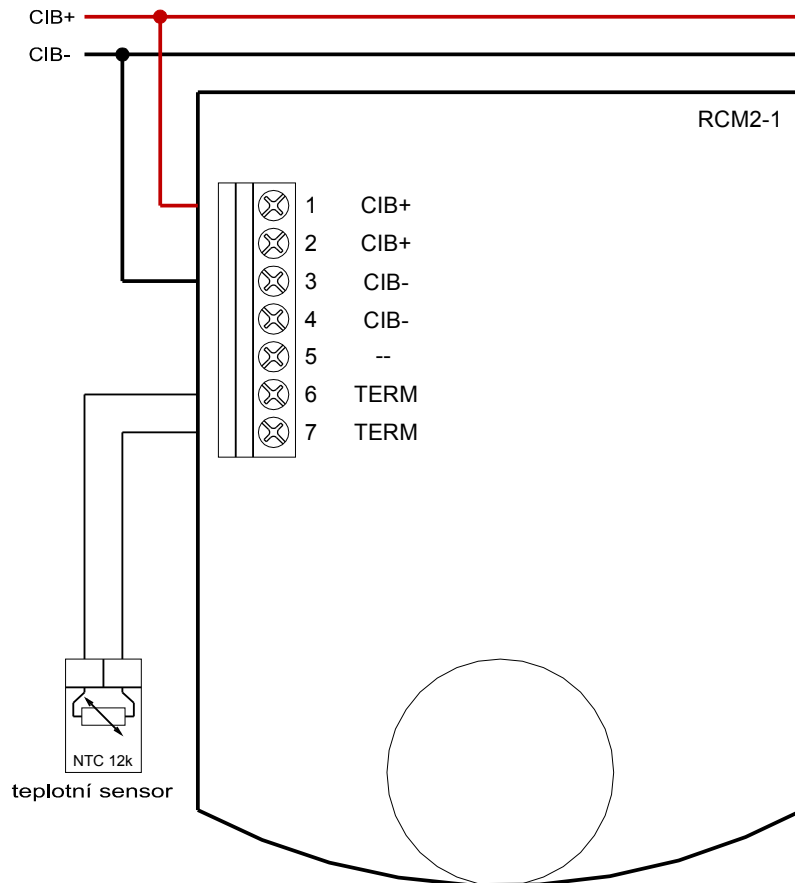

Fig. 9.2.2.2 Example of connecting RCM2-1 module including temperature sensor

### **9.3 Infrared control**

The C-RI-0401S module as IR code receiver/transmitter is available on CIB. The module consists of two parts. Built-in part contains electronics and plug to connect external transmitter, receiver, light sensor or button.

The built in part enables to be placed anywhere e.g. under the cover of devices like air conditioner or so. It enables also to install IR receiver and IR transmitter separately on different walls of the same room.

The built in part can be combined with the upper visible part which is available in Time design by ABB as a standard. All other designs can be customized according the order.

### 9.3.1 IR transmitter and receiver C-RI-0401R-Time with the design on the wall

Module C-0401R-RI-Time contains IR transmitter and receiver. Both are designed to sense and generate signals to control different types of devices such as air conditioning units. It can learn the IR commands of different IR remote controls, save it and release again under control of Foxtrot

It can be used for Air conditioners, audio video devices and others with IR control.



## 10 Temperature measuring

Various temperature like outdoor, indoor, in pipeline etc. can be measured by wide range of modules of CFox wired and RFox wireless system. To help to understand all variants the overview table of modules and plug types of temperature sensors as well as other analog values can be found below.

RANGE MODULE														
	Pt1000	Ni1000	NTC 12k	NTC 5 ÷ 15k	KTY 81-121	0÷20 mA	0÷10V	Termocouples	Condensation	Internal sensor	RTD 0÷600 KΩ	RTD 0÷6 MΩ	DI, dry contact	Balanced inputs
C-IT-0200R			1							1				
C-IT-0200S	2	2	2	2	2								2	2
C-IR-0202S	2	2	2	2	2								2	2
C-IT-0504S	5	5	5	5	5								5	5
C-IT-0908S														
C-RC-0002R			1	1						1				
RCM2-1			1							1				
C-IT-0200I	2	2	2	2	2	2	2	2		1				
C-IT-0100H										1				
C-HM-0308M	3	3	3		3				3		3	3		
C-HM-1113M	3	3	3		3				3		3	3		
C-HM-1121M	3	3	3		3				3		3	3		
C-HC-0201F-E	1	1	1	1	1					1				
C-WS-0200R			2	2										
C-WS-0400R			2	2										
C-FC-0024X			2	2										
C-VT-0102B			2	2										
C-AM-0400M	4	4	4	4										
C-AM-0600I	5	5	5	5					1				5	
C-RI-0401	2	2	2	2	2				0/1				2	
R-IT-0100R										1				
R-IT-0100H-A										1				
R-RC-0001R			1							1				
R-HC-0201F			1							1				

Tab. 10.1 Overview of CFox and RFox modules with temperature sensing

## 10.1 Room temperature measuring

Room temperature can be measured in several ways. It depends on the requirement of form factor, on design of measuring element, whether to measure temperature of the floor at the same time, whether bus or wireless modules (CFox, RFox) are preferred. Also can be preferred direct connection of temperature sensors to the DIN rail modules with analog input in the central. Room temperature is measured by the wall heating control modules. The C-RC-0002M and RCM2-1 measure the temperature always. Also CFox wall switch modules C-WS.... can attach the temperature sensors.

### 10.1.1 Temperature sensor as CFox module in the wall design.

For many designs temperature sensors are available in the wall design compatible with the wall switches.

The module consists of two parts. Built-in part contains electronics and gas 4-wire cable to be connected to CIB and to connect external temperature sensor. It has also the plug to insert the cable from the upper part – the cover in the customized wall design. The cable length is 70 mm with connector. The external temperature sensor (NTC 12 k or NTC <100k ) can be used for floor temperature measuring.

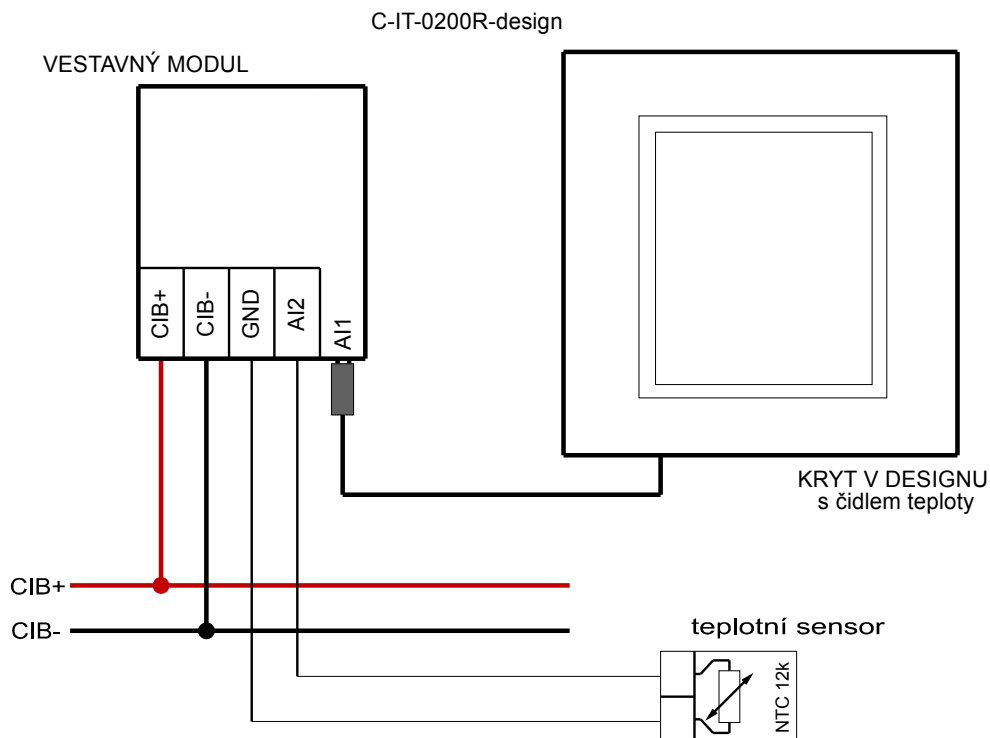

Fig. 10.1.1.1 Example of temperature sensing module C-IT-0200R-design, for room and floor temperature.

#### Notes:

- 1) External temperature sensor must be NTC 12k type or other NTC <100kOhm, the length of cable can be up to tens of meters - typical use of cable for floor sensor is SYKFY 1x2 wires with diameter of min. 0.5 mm.
- 2) The build in part of the module is designed as a small one into a standard flush box (KU68). The module has four wires of length about 10 cm for CIB and external temperature sensor plus a small connector to plug the sensor from upper module - the cover in the wall design.

### 10.1.2 Temperature sensor as CFox module in the ABB wall design

Version for ABB designs is available. The C-IT-0200R-ABB, with order No. 133 TXN 19.01, Time White/white is a standard in CFox system. The variations of colors of covers, frames and different ABB designs are available according the customized order.

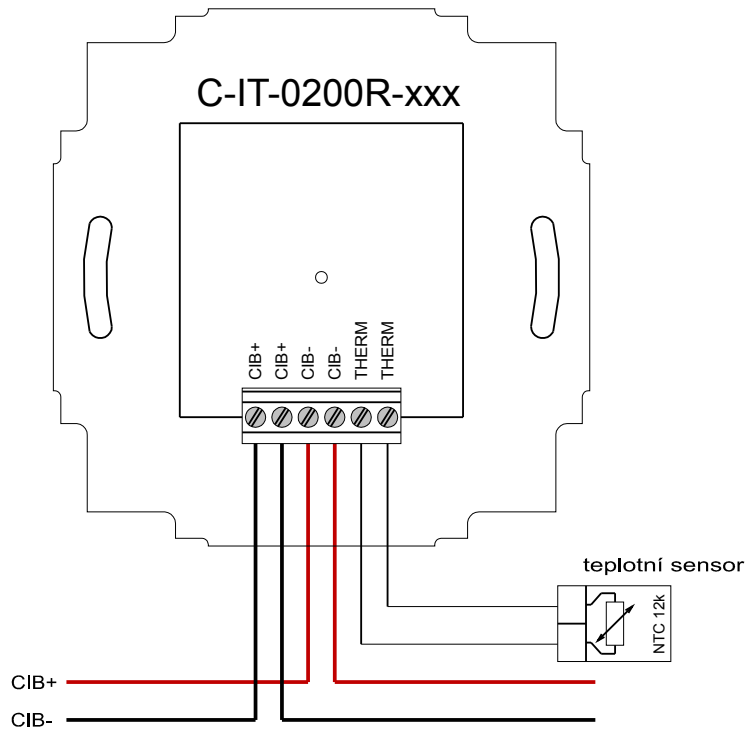

Fig. 10.1.2.2 Example of connection – room and floor temperature measuring with C-IT-0200R-ABB, TXN 133 19

#### Notes:

- 1) External temperature sensor must be NTC 12k type or other NTC <100kOhm, the length of cable can be up to tens of meters - typical use of cable for floor sensor is SYKFY 1x2 wires with diameter of min. 0.5 mm.
- 2) Module is designed as dummy in ABB design. The terminals are on the backside of module to be fixed into a standard flush wall box (KU68). The depth of module is about 12mm.

## 10.2 IP65 temperature measuring

Temperature in the other parts of building especially technologies as the heat source, solar systems, outdoor temperature or in the pipeline can be measured in several ways.

There are temperature sensors in IP65 housing with embedded CIB interface:

C-IT-0100H-P with the plastic head with the immersion sleeve

C-IT-0100H-P with the plastic head with the immersion sleeve, for higher range of temperatures

R-IT-0100H-A with the metallic head and battery with immersion sleeve etc.

You can use the standard temperature sensors available on the market like Pt1000, Ni1000, NTC etc. which can be connected to analog or universal inputs of a many CFox and RFox modules or directly to the inputs on Foxtrot basic module eg. CP-1006, CP-1008. The range of sensors available are in the price list, the suitable modules are in [Tab 10.1](#).

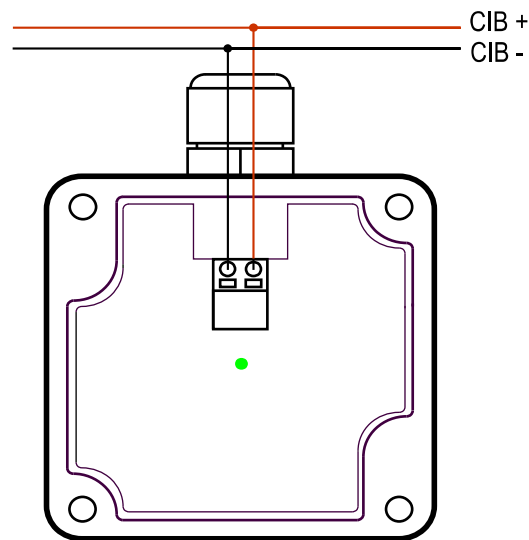

Fig. 10.2.1 Example of connection of C-IT-0100H-P with plastic head

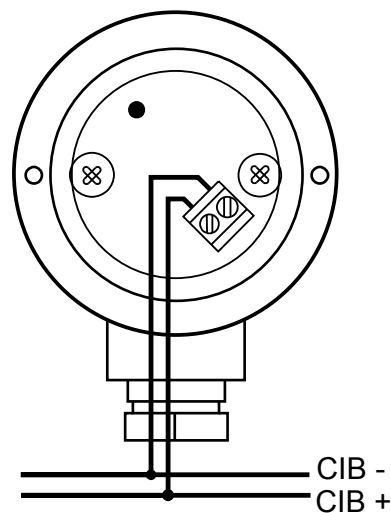

Fig. 10.2.2 Example of connection of C-IT-0100H-A with metallic head

## 11 Metering - energy and non-electric values

### 11.1 Electric energy measurement by pulses

To measure the energy costs (eg monitoring the consumption of heat pumps) can be used any meter with SO output. Example of connecting the SO output of one phase meter ED-11.M to C-AM-0400M is on figure below.

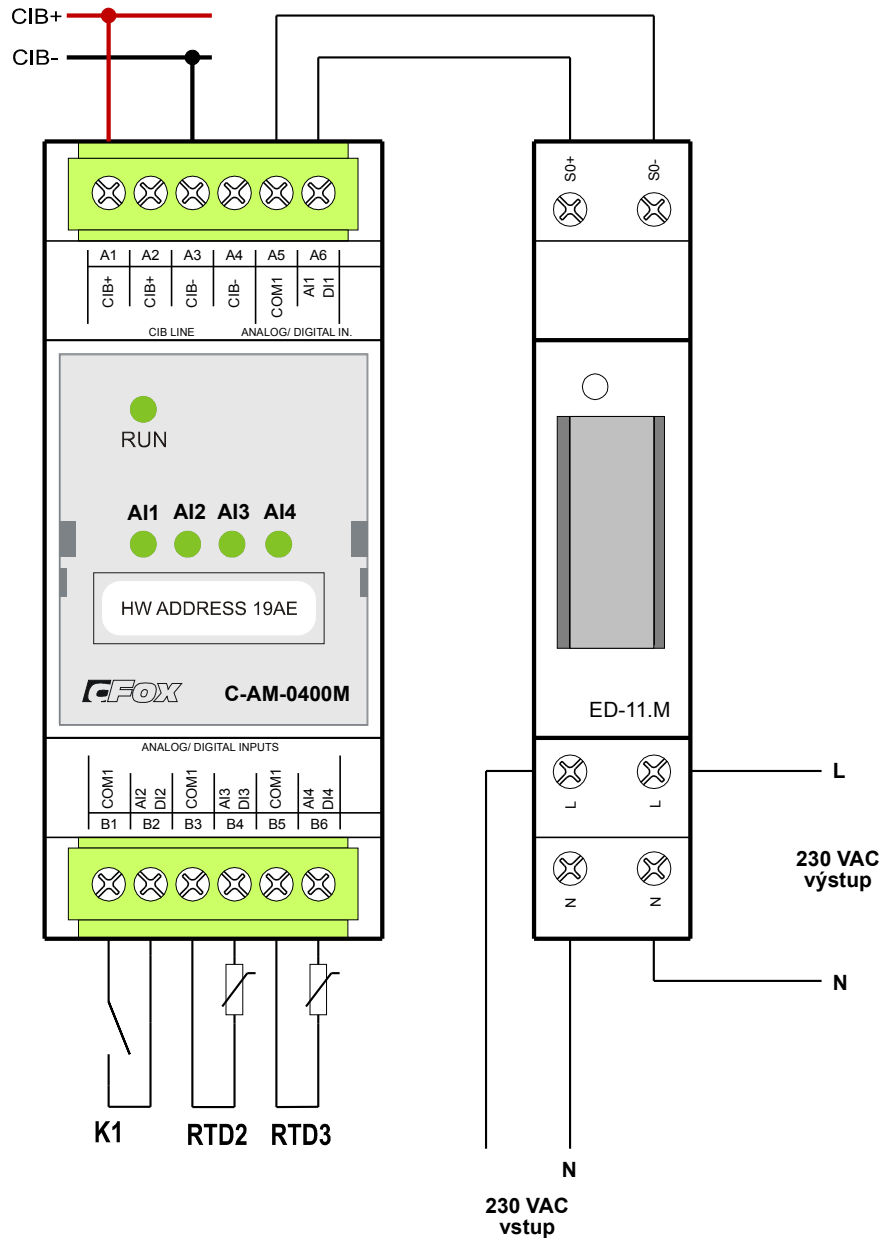

Fig. 11.1.1 Example of reading SO output of ED-11.M meter by C-AM-0400M module

## 11.2 Electric energy measurement by reading data by optical head (EN 62056-21)

Optical interface TXN 149 01 (also optical head) is designed for reading and communicating with the meter, HDO (ripple control) and other devices via standardized optical interface. The probe converts bidirectional optical signals of LED into serial port RS-232 (RxD and TxD). Its main purpose is to facilitate communication with energy meters, ripple control receivers or other devices equipped with an optical interface according to standard EN 62056-21. The probe includes a galvanic isolation of transmitter and receiver.

The probe has a built-in toroidal magnet, which allows the removable attachment to the surface of meter and the centering of the optical interface location. The optical probe is to be connected to the serial port of Foxtrot by the cable with separated wires.

The interface is connected to screw terminals RS-232 basic module TECOMAT. For more information on communication channels Foxtrot, see the [documentation \[4\]](#).

Probe TXN 149 01		PLC Foxtrot	
Color of wire	signal	signal	Terminal on CH1
green	RxD	TxD	A8
red	TxD	RxD	A7
white	+24V	+24V	A4
blue	GND	GND	A3

### **11.3 Heat and flow measurement**

To measure the heat (eg heat produced by the solar system) flow-meters with integrated temperature sensors can be used. Standard water meters for cold or hot water with the pulse output can be used. It is possible connect the pulse outputs to inputs of C-AM-0400M or C-AM-0600I, These water-meter pulses should be completed by two temperatures (output and return) to have all values to calculate heat delivery as a part of application program. Such water meters can also be used for flow measurement (eg, monitoring of leaking water at the weekend house or so).

The AV-23 flow-meter with simultaneous temperature measurement of media can be connected to C-AM-0600I. The second temperature sensor has to complete the system in order to calculate heat consumption. This flow-meter has no moving parts so the advantage is in greater range of temperatures and viscosity media, making it suitable for the primary circuit of solar system.

## 11.4 Air quality measurement

The modules of CO<sub>2</sub>, smoke, VOC (volatile substances) concentration and RH (relative humidity) measurements are available. All that modules are mechanically identical. Also connection to CIB is the same.

Module C-AQ-0001R is a sensor of concentration of carbon dioxide CO<sub>2</sub> in the air. The measurement principle is based on infrared radiation attenuation dependent on the concentration of CO<sub>2</sub> (Non Dispersive Infrared Radiation absorption). The concentration of CO<sub>2</sub> is a signature of the air quality in the room and thus can be used e.g. to control ventilation in rooms and buildings. The module is designed for wall mounting or installation on the flush box.

The module measures two inputs. The first one is for CO<sub>2</sub> sensor. The second one is for temperature sensor, which is intended only for orientation and maintenance purposes. The sensor measures the temperature inside the device and gives information about the operating conditions of the module.

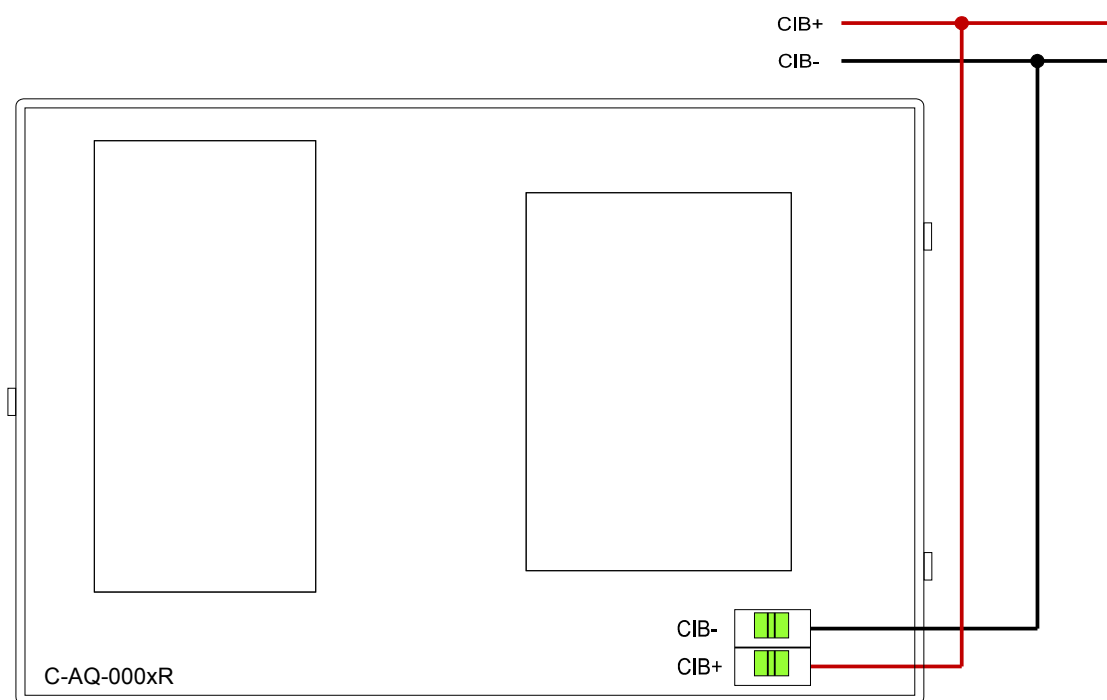

Fig. 11.4.1 Example of connecting air quality sensors C-AQ-000xR



### 11.5 Mains parameters measurement

The SMM 33 module can be used for detailed analysis of the 3phase power network in terms voltage, current, active and reactive power, etc.. It has to be connected to the serial port RS 485 of Foxtrot. For more information about serial ports see the [documentation\[4\]](#).

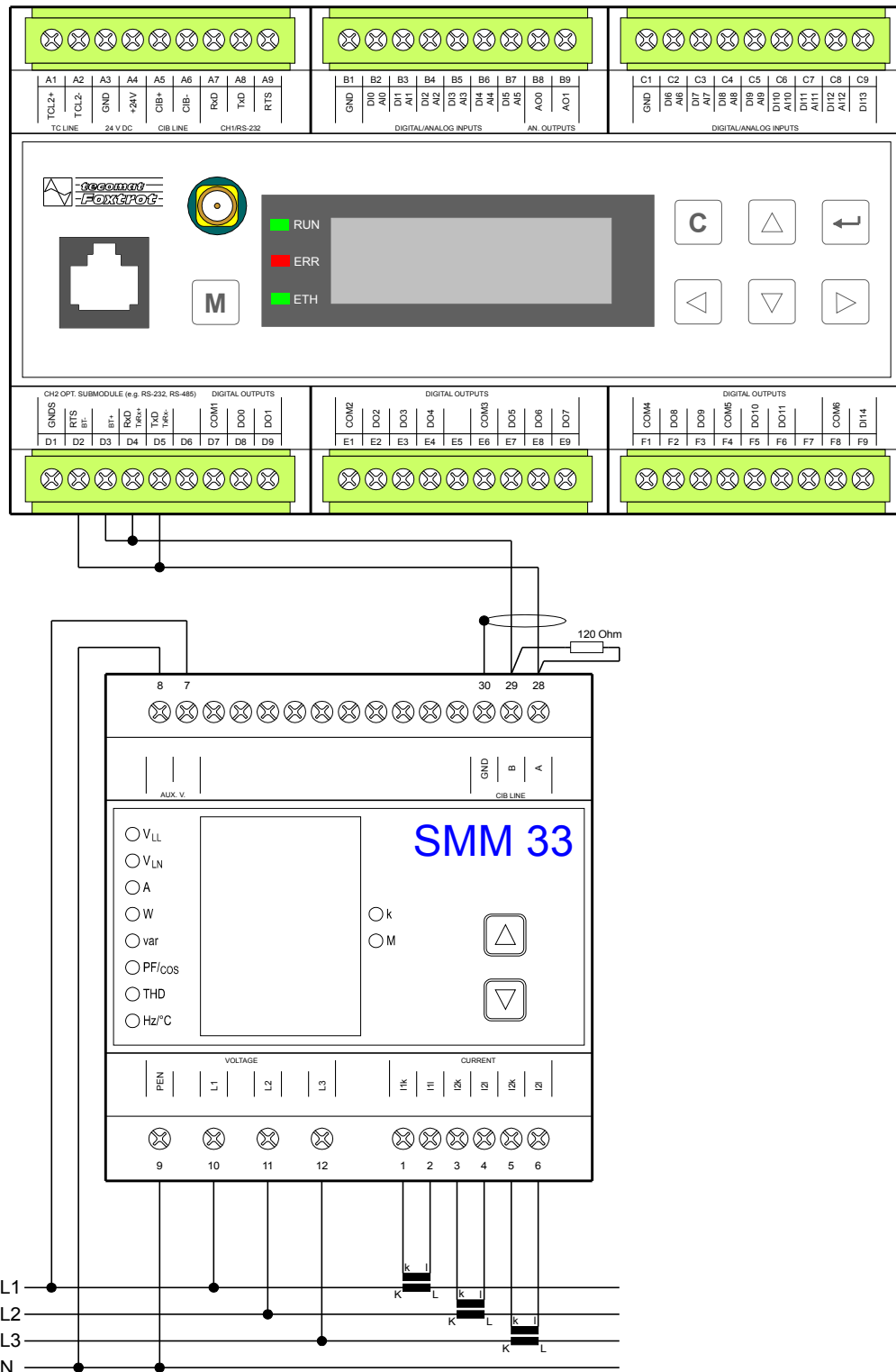

Fig. 11.5.1 Example of connection of SMM 33 - analyzer of 3phase power network.

## 11.6 Weather station measurement

Weather stations integrated in anemometer - GIOM3000 enables to measure the primary weather values:

- Wind speed and direction,
- Humidity
- Temperature
- Atmospheric pressure

and derived variables:

- Barometric altitude,
- Relative pressure QNH / QFF,
- Beaufort,
- Windchill,
- Saturated vapor pressure,
- Absolute humidity  $\text{g/m}^3$  and  $\text{g/kg}$ ,
- Dew point.

In Foxtrot there is SW library supporting the integration of GIOM3000 weather stations data into the management of different tasks in the house including monitoring and displaying.

Weather station is to be integrated via 10M Ethernet interface with POE (Powered Over Ethernet). It is possible to insert it directly to LAN switch with POE in case the supply voltage does not exceed 30VDC. Power supply can be realized also by POE Splitter module with AC adapter when POE Splitter combines a standard Ethernet with power supply for the weather station. Then the weather station requires to be supplied from standard power adapter from the mains socket. The only connection is by shielded UTP cable via RJ45 connector

Dimensions 250 x 277.6 x 77.9 mm.

POE Power 12V/60mA

Operating temperature -30 to +60 ° C



Fig. 11.6.1 Weather station GIOM3000

## 11.7 M-bus meters integration, SX-1181 module

SX-1181 is a module designed to connect up to 64 devices equipped with an M-Bus (EN 1434) - usually heat meters. The mechanical design is suitable for installation on the DIN-rail (EN 60715). The module is equipped with fixed screw terminals and has to be connected to the serial port RS232 on the basic module Foxtrot. M-Bus interface is to be connected to the screw terminals.

M-bus interface is powered by 24 V DC / 30 to 150 mA. Consumption depends on the number of connected devices. RS232-Bus and M-bus are mutually isolated with insulating voltage of 1 kV.

### M-Bus

is the bus designed to connect heat meters and similar power meters. This bus should be able to power all connected meters and enable remote reading of measured data. The physical layer is defined by EN 1434, link layer according to IEC 870 and application layer according to standard CEN TC 176.

The bus is realized by two wires, from which the meter can be powered and communication can be provided. Meters are connected in parallel way on the bus regardless of the polarity connection since most of meters do not take care about the polarity. (see connection requirement of the meter manufacturer), the topology is the bus, length up to 4 km, the maximum number of meters connected to the bus is 250. Each meter has a unique network address. Max. communication speed is 38400 baud. The limitation is due to cable length and to number of connected meters.

The idle status of the bus corresponds with the voltage of 36 V DC. Master (in our case, the SX-1181 module) transmits data by changing voltage between 36 / 24 VDC. Slave (heat meter) is acknowledging and answering by the change of current consumption between 1.5 / 20 mA (in the idle state it takes 1.5 mA according to standard).

The voltage and current on the bus is outlined in Figure 11.7.1.

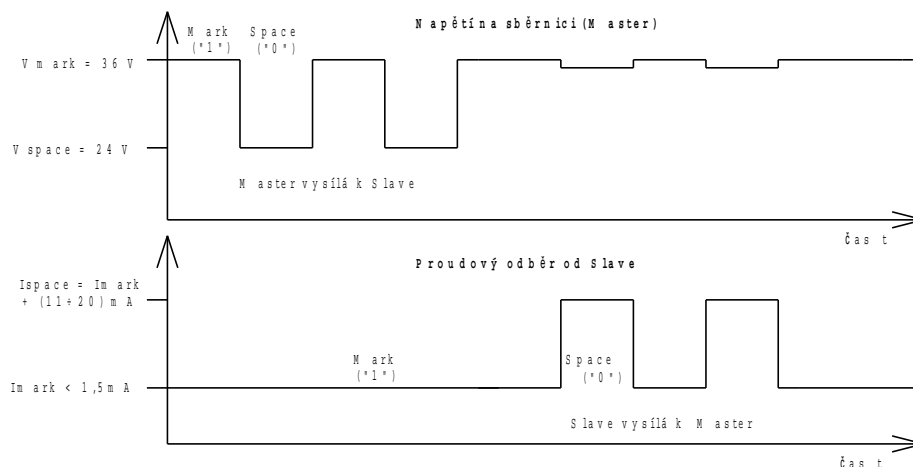

Fig. 11.7.1 M-Bus timing and levels

The modules providing conversion to M-Bus interface are divided by the "M-Bus User Group" into several categories. Module SX-1181 corresponds to the middle category of converters.

Example of M-bus module wiring to the basic Foxtrot is shown below. The serial port CH1 with RS232 interface is connected to module SX-1181. If the modules are not side by side, the shielded cable is recommended. M-Bus interface can be powered from the same power supply, though it is not necessary to separate the heat meter electrically. Otherwise, this part can be powered from a separate source.

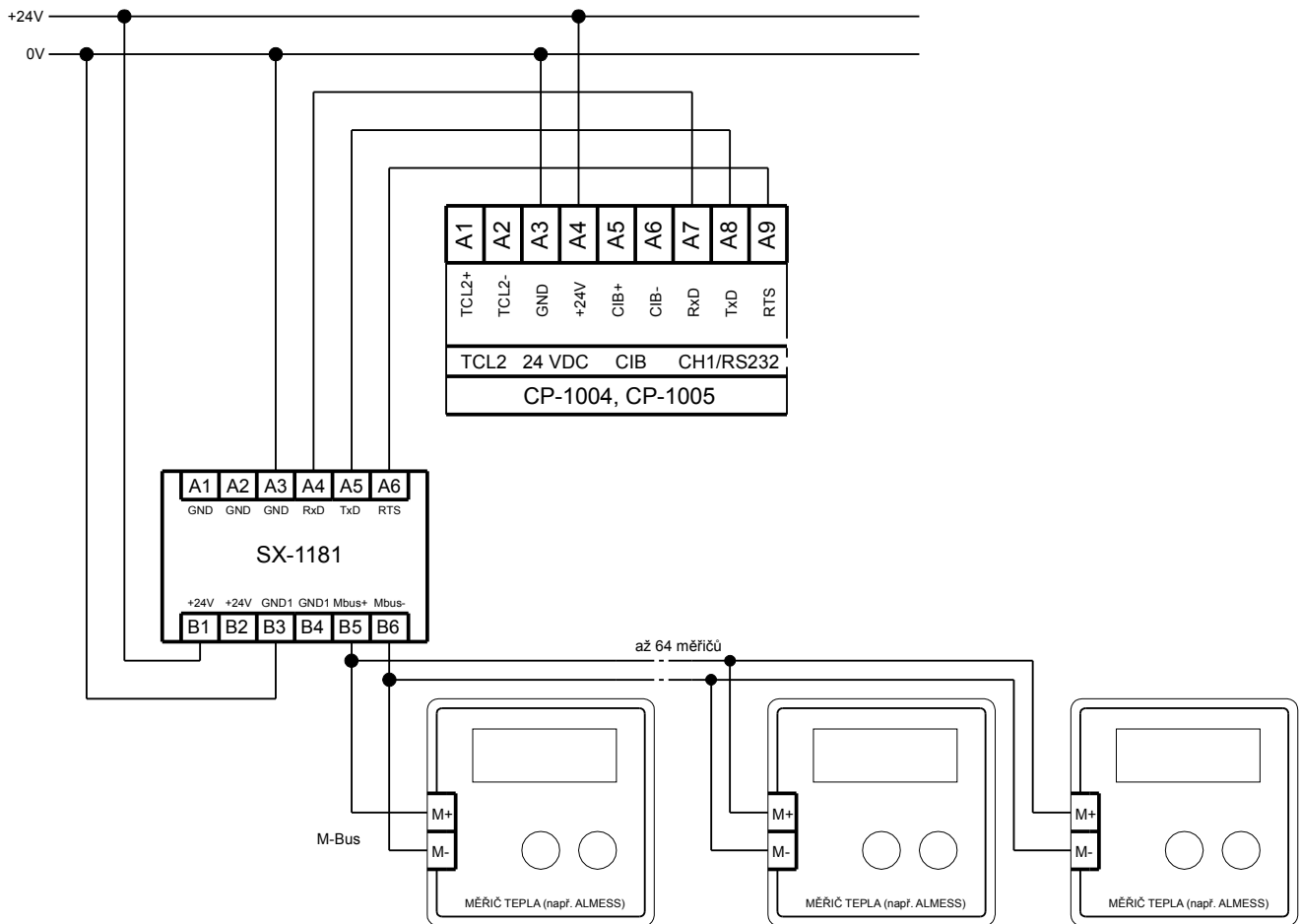

Fig.. 11.7.2 Connecting the SX-1181 module to serial port CH1 of CP-1004 module

Notes:

- 1) Up to 64 meters can be connected to the SX-1181 module. This implies a maximum idle current of 96 mA bus. The total consumption module is up to 150 mA.
- 2) The maximum M-Bus cable length is 350 m as standard. In case of maximum line resistance  $<30 \Omega$  and maximum capacity of 0.82  $\mu\text{F}$  the total length can be up to 4 km. The max speed is 9600 Bd, recommended speed is 2400 Bd.
- 3) The recommended cable is a standard telephone type with wire diameter 0.8 mm. The shielded type like JYSTY 1x2x0,8 is recommended. Shield should be connected on SX-1181 side to the protective earth PE.
- 4) Module SX-1181 is a "modem type" device, so the TxD terminal on SX-1181 has to be connected to the TxD terminal on Foxtrot. The same is valid for RxD and RTS signal. Do not cross the signals!
- 5) Terminal GND1 (B3, B4) and GND (A1, A2, A3) are electrically isolated. If the module is powered from a separate source connected to terminals +24 V and GND1, the GND terminal has to be connected on the ground terminal of the RS-232 interface on the basic module.

## 11.8 M-bus meters integration – MR-0158 sub-module

Sub-module MR-0158 is a physical layer of M-bus interface for master side of the metering bus. More details of the M-bus see the previous chapter. The M-bus is usually used for reading the heat meters, electricity meters etc.

The sub-module can be used in TECOMAT: Foxtrot, TC700 series, TC650, TEMPO, each with the free slot for serial interface sub-modules.

Length of M-bus is limited by the maximum voltage drop on each wire (should not exceed 0.5 V), which is dependent on consumption of idle slaves (the number of modules x 1.5 mA) and cross-section of wires. Overload lines M-bus fuse disconnects the built-in converter for about 1 second. Then it try again activate normal function. This state is indicated by the DCD or by CTS signal to log.0. After the overload the fuse itself goes back to normal function.

The module as master interface allows to handle with max. 20 M-bus slaves. Power supply of M-Bus has galvanic isolation from other circuits.

SCH2 interface has the free slot for inserting sub-modules similar to MR-0158 so the terminals have different signals for different sub-modules. See the following pictures.

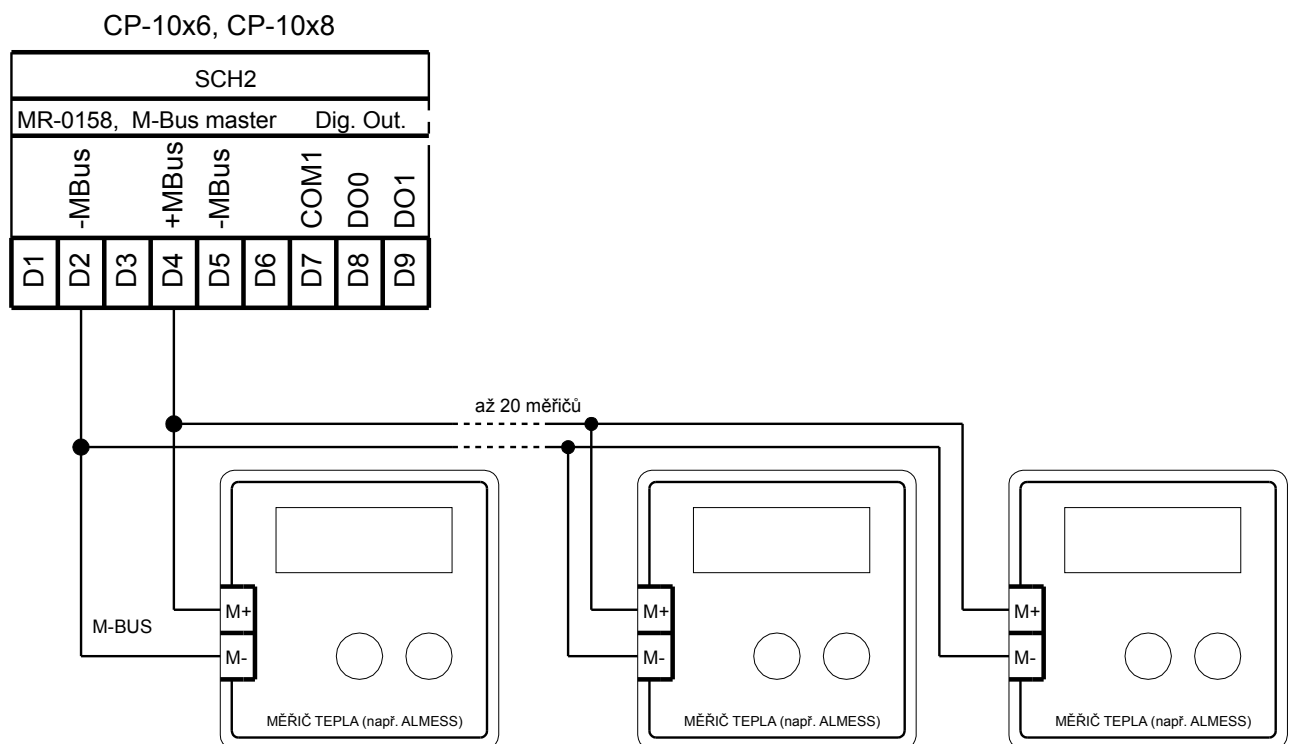

Fig. 11.8.1 Connecting the M-Bus meters to CP-10x6, CP-10x8 to SCH2 interface with inserted MR-0158 sub-module.

### Notes:

- 1) Max. 20 meters can be connected to MR-0158 interface sub-module
- 2) Max. M-Bus cable length is 350 m as standard. If the max. voltage drop is < 0,5V at each wire, up to 4 km line can be reached.
- 3) The recommended cable is a standard telephone type with wire diameter 0.8 mm. The shielded type like JYSTY 1x2x0,8 is recommended. Shield should be connected on MR-0158 side to the protective earth PE.

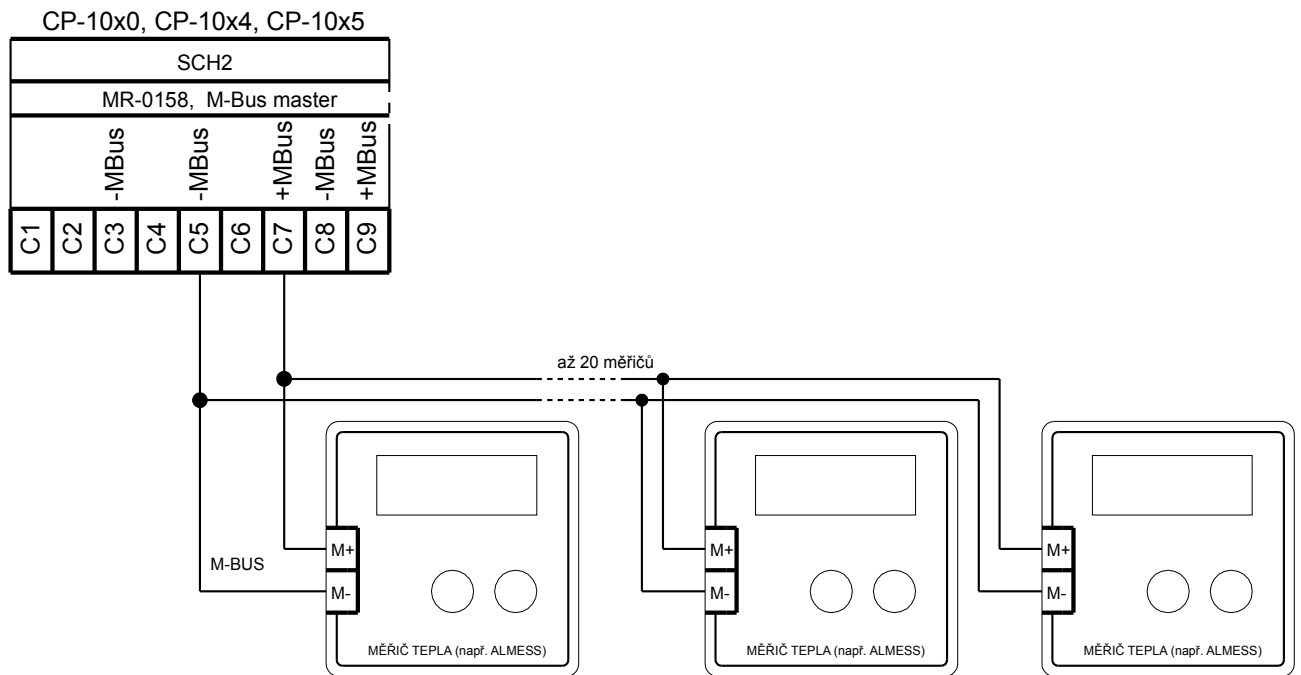

Fig. 11.8.2 Connecting the M-Bus meters to CP-10x0, CP-10x4, CP-10x5 to SCH2 interface with inserted MR-0158 sub-module.

Notes:

- 1) Max. 20 meters can be connected to MR-0158 interface sub-module
- 2) Max. M-Bus cable length is 350 m as standard. If the max. voltage drop is  $< 0,5V$  at each wire, up to 4 km line can be reached.
- 3) The recommended cable is a standard telephone type with wire diameter 0.8 mm. The shielded type like JYSTY 1x2x0.8 is recommended. Shield should be connected on MR-0158 side to the protective earth PE.

## 11.9 Water level measurement

In Foxtrot system large number of level sensors can be used for analog measuring or limit monitoring of water – in wells, in tanks for rain water or in pools.

### 11.9.1 Water level continuous measurement in the well or in tank

For continuous level measurement of non-aggressive liquids in non-pressure tanks, boreholes, wells, pools, etc. it is suitable to use hydrostatic level meter, such as HLM-25S by Dinel. The height of liquid column up to 100 m can be measured by HLM-25S. It is approved for usage for a drinking water and is equipped with surge protection inside the probe. The sensor can hang in a tank on cable. Cable is equipped with a capillary to compensate the hydrostatic pressure and with two-wire of measuring and supplying current loop  $4 \div 20$  mA. An example of connection to the module C-IT-0200I is below.

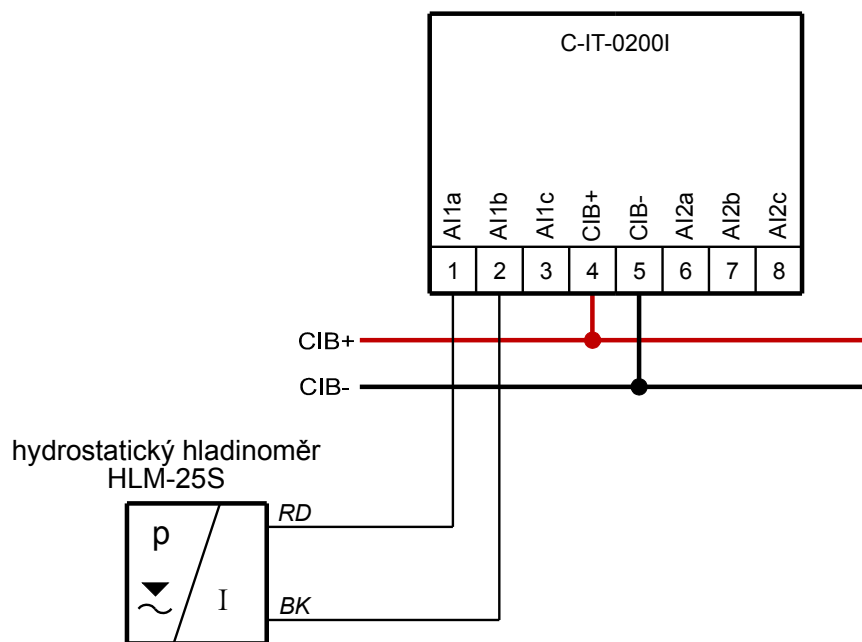

Fig. 11.9.1.1 Connecting the level meter HLM-25S to C-IT-0200I to read level over CIB.

#### Notes:

- 1) Installation of level meter is done by dropping the probe into the measured area (tank, well). The probe can hang on the cable, or it can lay at the bottom
- 2) The cable contains capillary buffer, so it is necessary to take care about the proper connection to the extension cable or to CIB module. The non hermetic case should be used. Tapping the extra cable in the bundle keep the circle diameter min. 30 cm. The manufacturer does not recommend shortening the probe cable or otherwise mechanically modify it.
- 3) Module C-IT-0200I can be placed close to the tank since it has higher protection IP-65.
- 4) For extension cord it is recommended to use the shielded cable e.g. JYSTY 1x2x0.8. Shielding should be connected to protective earth at the side of CIB module.

### 11.9.2 Water level limit monitoring in the well or in tank

Either continuous measurements in accordance to previous section or directly limit sensor can be used to guard the minimum and maximum water level in the tank, well, etc.

Capacitive level sensor CLS-18S-11 by Dinel can be used for monitoring a minimum water level in the well . It is submersible IP-68 level sensor to sense water in boreholes, wells and reservoirs. The sensor is suspended on a cable with stainless steel guard basket preventing mechanical damage of the electrode. Max. immersion depth is 100m.

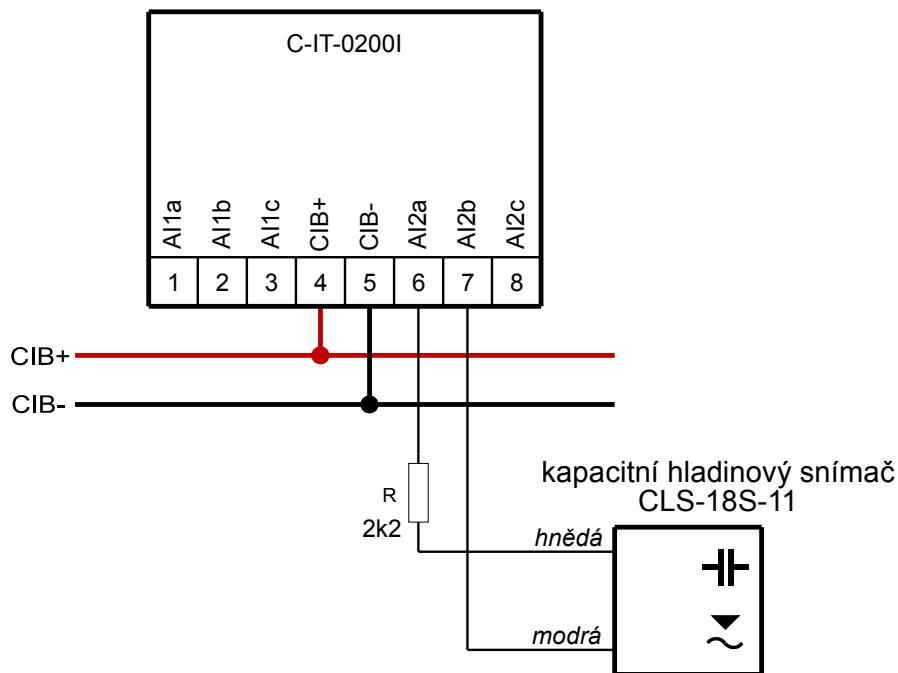

Fig. 11.9.2.1 Connection of capacitive level sensor CLS-18S-11

#### Notes:

- 1) The sensor is connected to the input of C-IT-0200I module which is configured for the measurement of current loop 4 to 20 mA via the serial resistor 2k2
- 2) Resistor value should be used between 1k8 and 3k3, the value of resistor can change the level limit of the measured analog value set by the application program. The resistor can be of any type and can be placed directly into C-IT-0200I module in area of terminals.
- 3) Probe cable of length up to 15m can be connect directly to module C-IT-0200I. It is recommended to use shielded cable (eg JYSTY 1x2x0, 8) in case of using extension cable. Shielding should be connected to protective earth PE at the side of the module.

Level limit detection in the tank can be done using a **conductivity probe** like CNP-18 by Dinel. It should be connected to the specific analog inputs sensitive enough like for condensation sensors which are part of C-HM-0308. To scan min. and max. level we need three probes with Istems so that we can evaluate the upper and lower limit. Resistance is always measured between two probes. For tanks made of conductive material one probe can be metallic tank enclosure itself.



## 12 Control and monitoring of other technologies in the house

### Coming soon:

Integration of camera surveillance  
Irrigation, water handling

### 12.1 Defrosting of outdoor areas

To defrost outdoor areas the electric heating cables are usually used. Defrosting can be controlled by Foxtrot according to the outdoor temperature, rainfalls, snowfalls. The temperature and humidity sensors has to be mounted in the treated area.

The system is activated if the temperature drop below the set value and other sensor detects the presence of snow or ice at the same time. The area is heated during snowfall or freezing rainfall and is kept at temperature above the freezing point so the ice is not forming. The system shuts down when the ice or snow is not detected or the temperature rises above the set value.

The parallel connection of two sensors increase the reliability of detection. Using two sensors will prevent tunnel effect when the layer of ice crust close the small space above the sensor to prevent contact with humidity.

Wiring example below considers the heated temperature and humidity sensor ESF 524 001 or ESF 524 011 by Eberle and a separate temperature sensor suitable for smaller areas. For larger areas, the unheated temperature and humidity sensor TFF 524 002 or TFF 524 012 can be connected accordingly. Heating cables can be connected to any relay output in the system with respect to switching power. Connection to the C-HM-0308 shows the following picture.

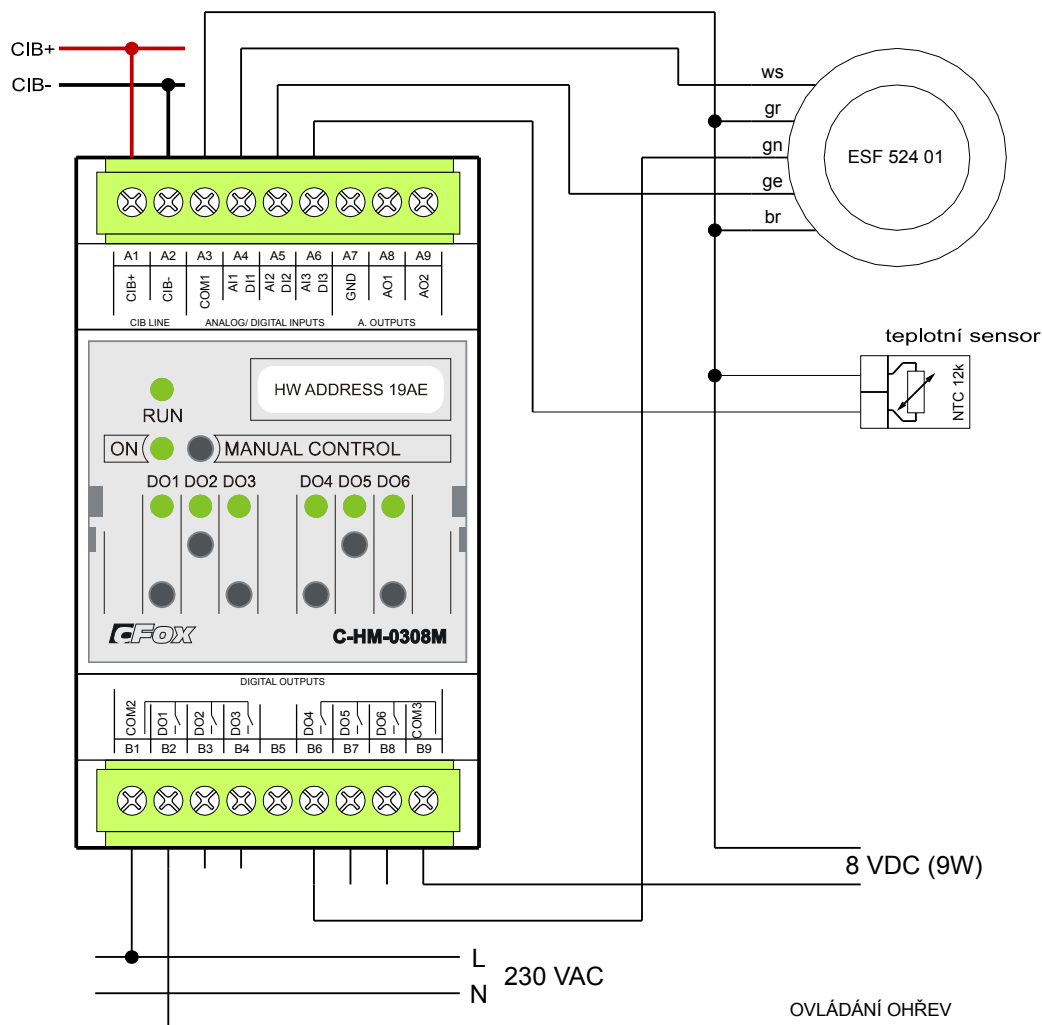

Fig. 12.1.2 Example of connecting sensors and heating cables for defrosting smaller areas

**Notes:**

- 1) Unheated sensor TFF 524 002 can be connected in the same way avoiding heating output DO4
- 2) Defrosting of pavement surfaces and gutters - both can be powered from a common power supply
- 3) By the similar way (according to manufacturer documents) the sensors of other manufacturers can be involved.
- 4) Relay output for heating is necessary to be chosen according to the actual switching power.

## 12.2 Defrosting of the gutters

To defrost the gutters electric heating cables are used. Defrosting can be controlled by Foxtrot according to the outdoor temperature and humidity

If the outdoor temperature falls below the set value and the simultaneous occurrence of moisture in any state - water, snow, ice is detected, the heating cables turns on. If the temperature rises above the set value or humidity disappears, the heating is switched off and heating cables are out of service. For sensing the temperature sensors has to be mounted near the gutter and humidity sensor directly into gutter near the seduction outlet.

If there is any moisture on the humidity sensor heating resistor dissolves it by 2W. To improve reliability of sensing, it is recommended to use two parallel humidity sensor. In such case appearance of moisture at one of them put the system into operation.

Wiring example considering a heated sensor ESD 524 003 by Eberle and NTC 12K (or NTC10k like TFD 524 004 sensor by Eberle). Sensors can be connected to any inputs of the system. Only humidity sensor is to be connected to the input for condensation measuring. See C-HM-0308 connection on the following picture.

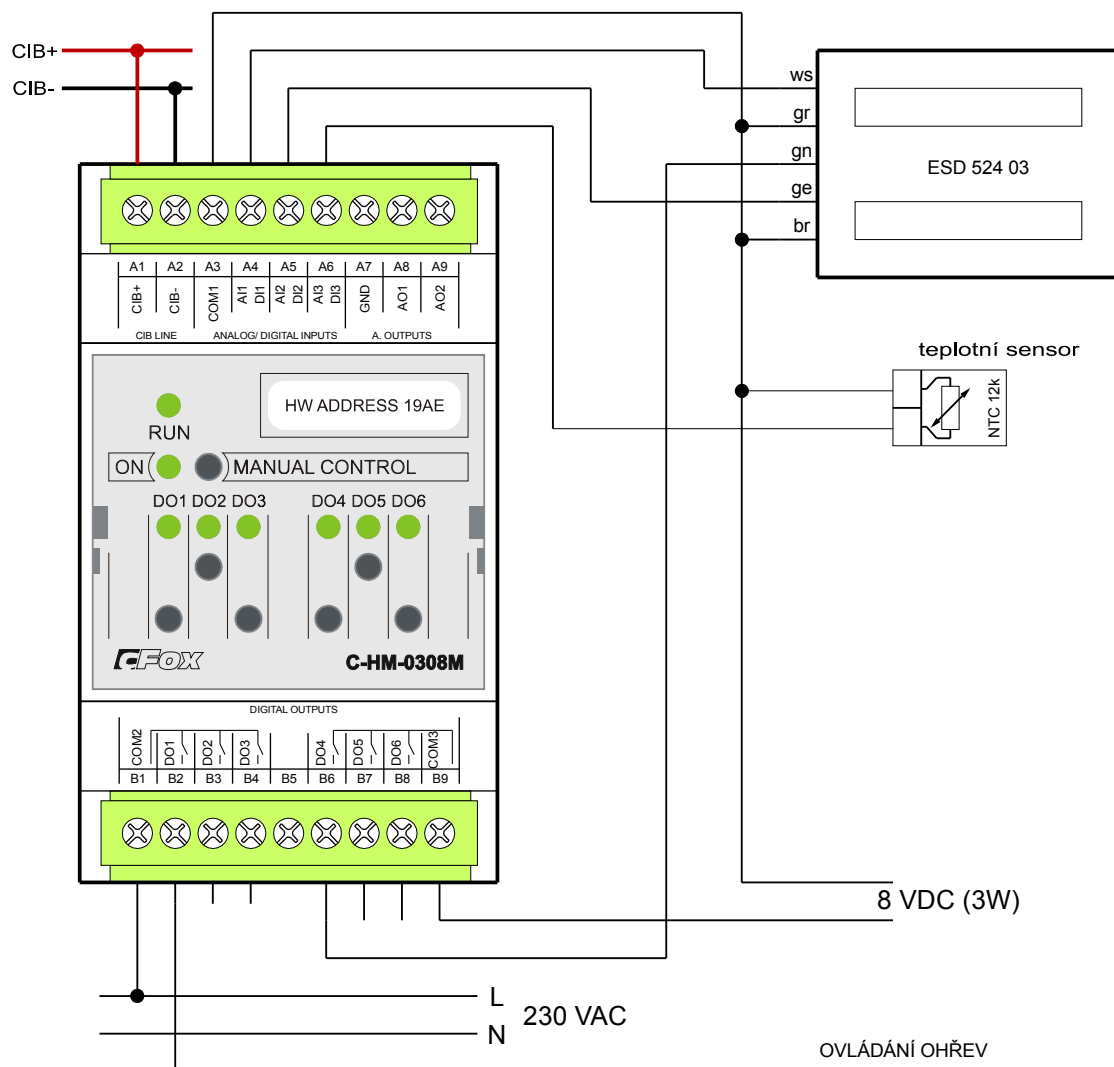

Fig. 12.2. Example of connecting sensors and heating cables for defrosting the gutters

Notes:

- 1) Defrosting circuits for gutters and pavement surfaces both can be powered from the same power supply.
- 2) Relay output for heating is necessary to be chosen according to the actual switching power.

## 12.3 Pool technology control, integration

### 12.3.1 pH and Redox (chlorine) measuring

To measure the acidity/alkalinity of the solution, or the concentration of substances in solution different types of sensors such as pH or redox probes are used. These probes have different types of outputs, which are mostly the current loop or voltage output. To sense these probes it is suitable to use C-IT-0200I module. It is equipped to measure both current loop and output voltage of the probes. Some probes convert the measured value of pH or redox to the current loop in the range  $0 \div 20\text{mA}$  or  $4 \div 20\text{mA}$ . The probes with the voltage output differs by the output voltage. Some of them convert the measured value to the standard range 0 to 10V, some of them provide the native output voltage directly from the probe.

In the case of measuring of native voltage of the probe the C-IT-0200I should be configured for ranges "HI-1V  $\div$  1V" and/or "HI-100mV  $\div$  100mV".

Measuring the native voltage of pH and redox probes is influenced by the high output impedance of that probes. So C-IT-0200I measures voltage of open circuit reduced by the voltage drop on the internal impedance of the probe.

Necessity of calibration arises from this fact. Calibration of both types of probes is accomplished using calibration solutions. First, dip the probe into the solution with a known value of the pH or redox (concentration), measure the value and subtract the corresponding voltage. This procedure is to be repeated for different values. Thus we get a set of values by which we can express the conversion characteristics of the couple sensor+input. From this calibrated characteristic the exact value of pH or redox can be derived. The calibration is not to be done in the full range but only for a few values. Usually we need to monitor the pH values out of the limits. So it is enough to know the values near these limits.

In the example redox probe SRH-1-PT-S6 with the 6m and pH probe SPH-1-S6 with 6m (both manufactured by SEKO) was used..

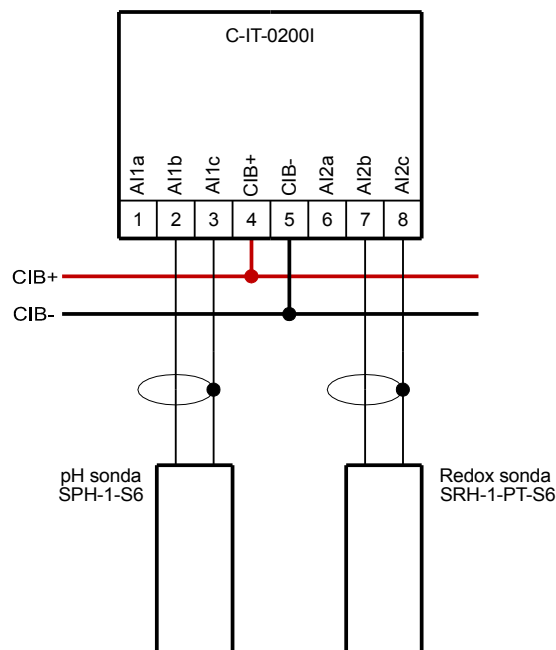

Fig. 12.3.1.1 Example of C-IT-0200I connection to measure pH and Redox potential (concentration)

## **13 Design and installation information**

### **Cumming soon:**

- Warming elements in the cabinet
- Surge protection
- Suppression components

### 13.1 Consumption of CFox modules from CIB or from external power supply

	CIB				Externí power supply							
					24 VDC				230VAC			
	Min. Power [W]	Min. Current [mA]	max. Power [W]	Max. Current [mA]	min. Power [W]	Min. Current [mA]	max. Power [W]	Max. Current [mA]	min. Power [W]	Min. Current [mA]	max. Power [W]	Max. Current [mA]
CF-1141	-	-	-	-								
C-IT-0200R-ABB	0,3	13	0,4	17								
C-IT-0200R-design	0,3	13	0,4	17								
C-IT-0100H-A	0,2	8	0,3	13								
C-IT-0100H-P	0,2	8	0,3	13								
C-HM-0308M	0,5	21	2,1	88								
C-HM-1113M	0,6	25	3,5	146								
C-HM-1121M	0	0	0	0							13,8	60
C-IT-0200I	0,3	13	1,5	63								
C-DL-0012S	0,5	21	2	83								
C-IR-0202S	0,4	17	0,6	25								
C-IT-0200S	0,25	10	0,3	13								
C-IT-0504S	0,5	21	1,9	79								
C-HC-0101F												
C-WS-0200R-Time	0,3	13	0,4	17								
C-WS-0400R-Time	0,3	13	0,4	17								
C-RC-0002R	0,3	13	0,4	17								
C-IT-0908S												
C-FC-0024X												
C-FC-0230X												
C-VT-0102B	0,3	13	6	250								
C-AQ-0001R	2	83	2,5	104								
C-AQ-0002R	1,3	54	1,5	63								
C-AQ-0003R	1,1	46	1,3	54								
C-AQ-0004R	1	42	1,2	50								
C-DM-0006M-ULED	0,3	13	0,35	15								
C-DM-0006M-ILED	0,3	13	0,35	15								
C-RI-0401S	0,4	17	0,5	21								
C-HC-0201F-E												
C-RQ-0400S												
C-AM-0600I												
C-AM-0400M												
C-OR-0102B												

Notes:

- 1) The current of the module is calculated at the nominal 24V DC power supply.
- 2) Minimum power consumption is considered for module turned on, all outputs open and inactive, the module does not supply any additional circuitry.
- 3) Maximum power consumption is considered for module turned on with all outputs (relay) closed and excited at the maximum current (Aout). All associated entries are in the active state, external circuits are powered.

## 13.2 Module dimensions

### 13.2.1 9M housing for DIN rail TS 35, according to EN 60715

Basic modules of Foxtrot, peripheral modules CFox, RFox

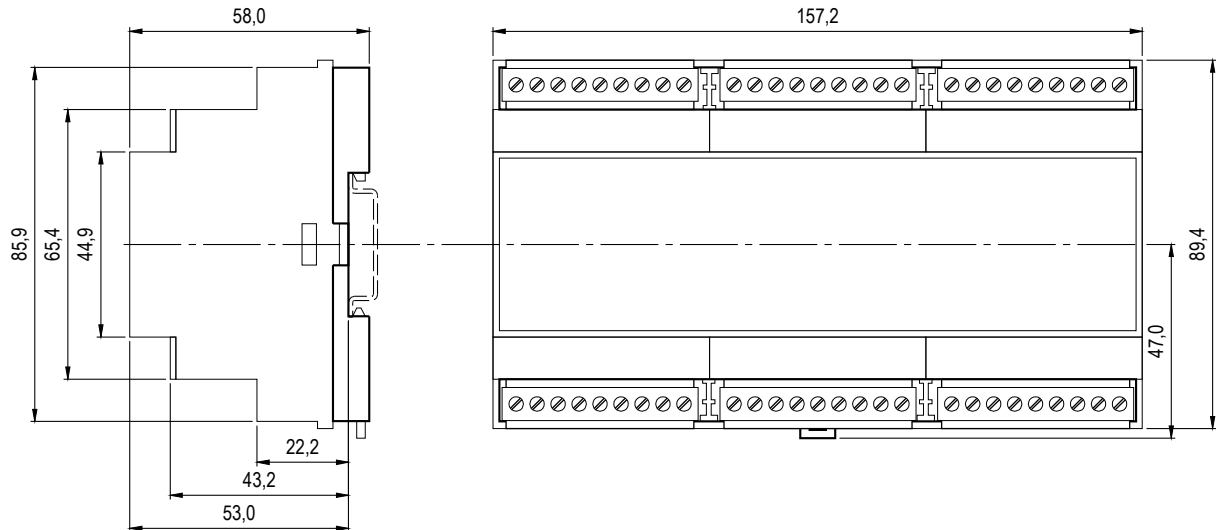

### 13.2.2 6M housing for DIN rail TS 35, according to EN 60715

Basic modules of Foxtrot, peripheral modules CFox, RFox

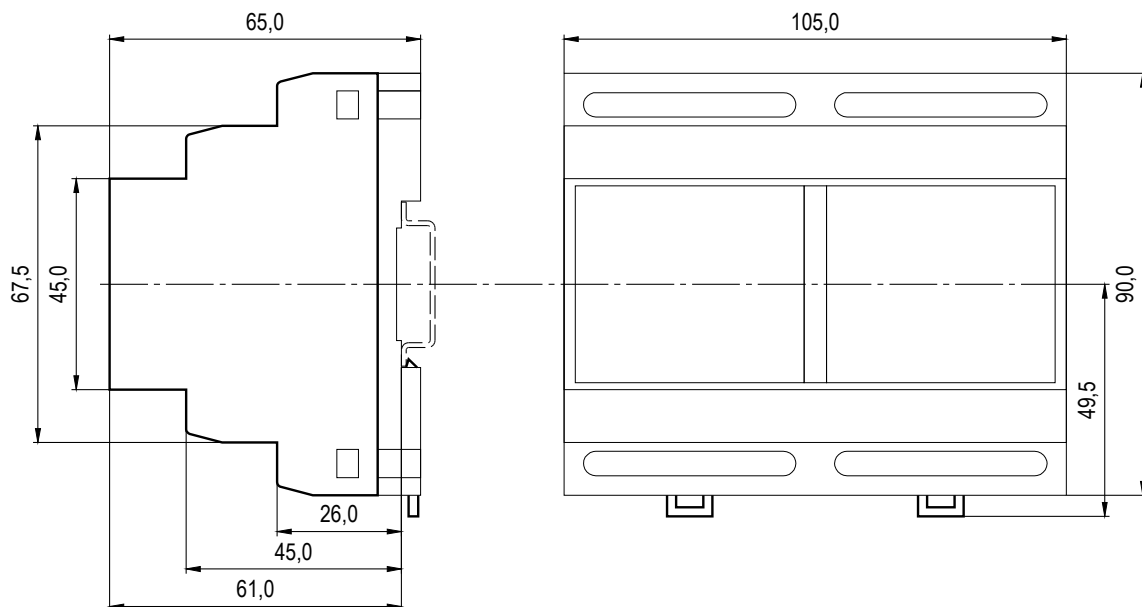

## **14 Basic application examples of CFox a RFox modules**

Following chapter brings the short description, connection and technical details of each CFox, RFox module. Chapter is organized according the module code.



### 14.1 C-OR-0008M, relay outputs, CFox

Module C-OR-0008M contains 8 relay, with all NO, NC contacts wired on separated terminals. The continuous current of each output is 16 A, the peak current is up to 80 A (for max. 20 ms).

The module is designed for switching capacitive (electronic power supply for LED lights, switching power supply, etc.) and inductive loads. Changeover contacts can be connected to secure three-point motor control such as louvers, actuators, etc. avoiding simultaneous powering of both outputs.

The module either can be powered directly from the CIB (its power limits the number of next modules at the same CIB branch) or can be powered from a separate source of 24V (which can be used for multiple modules located immediately next to each other). In the second case the CIB bus is not loaded by the module.

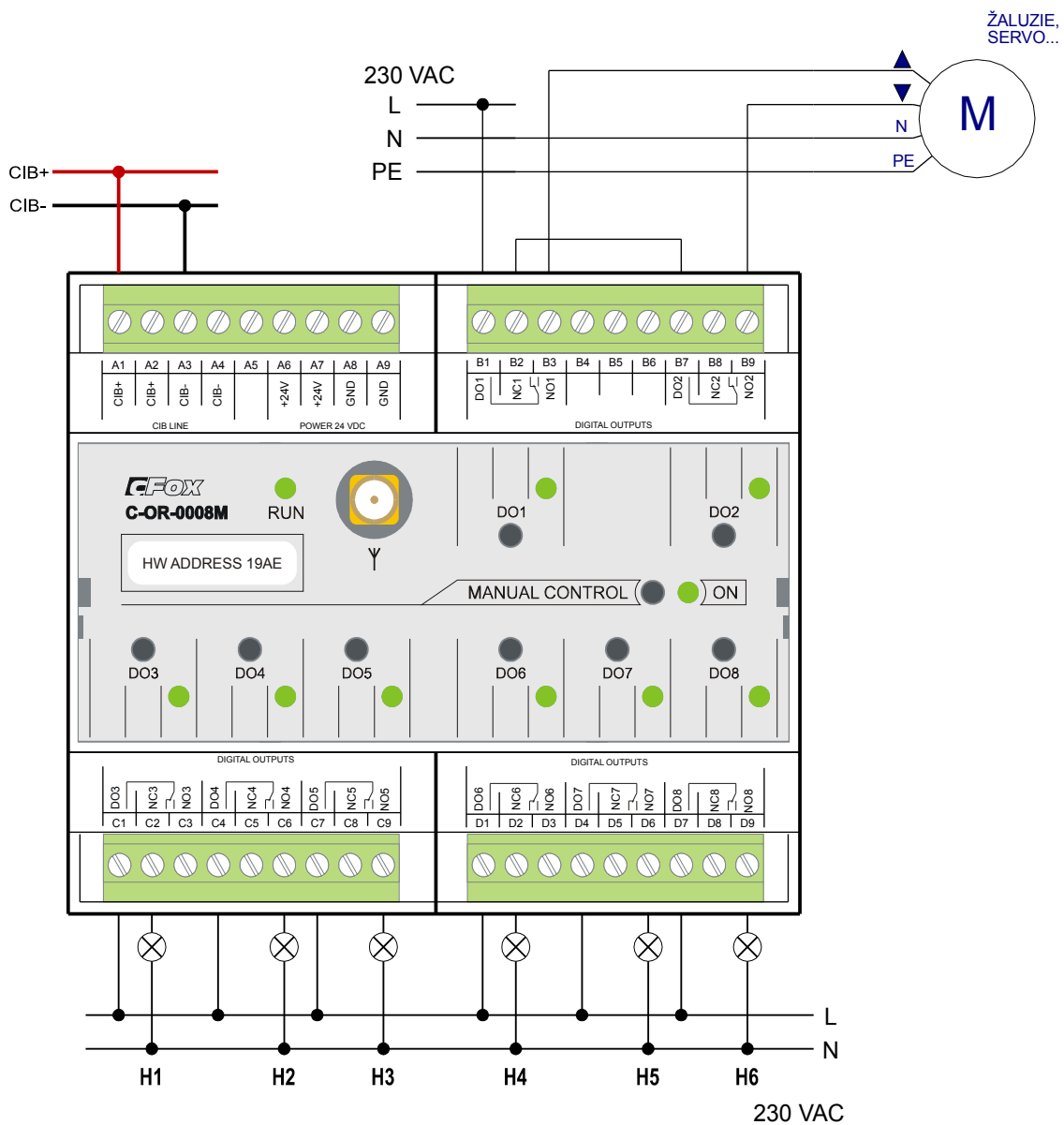

### 14.2 C-HM-0308M

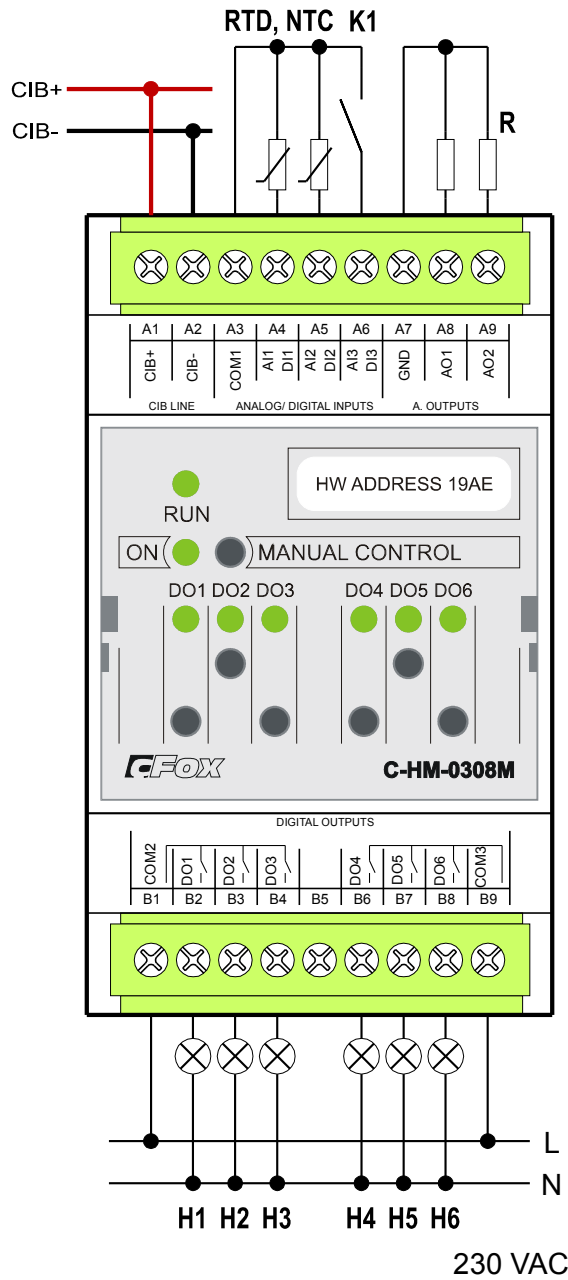

### 14.3 C-HM-1113M

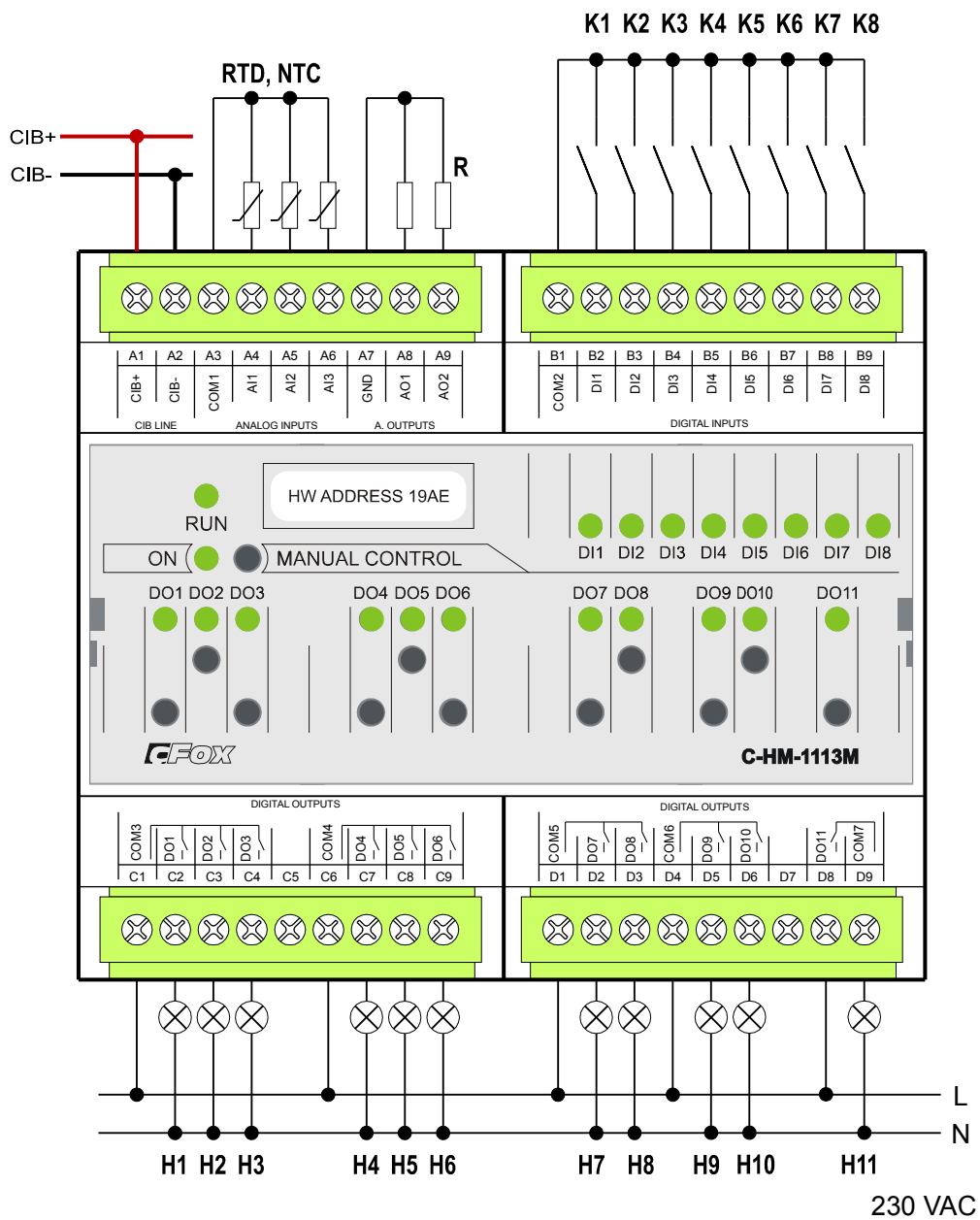

### 14.4 C-HM-1121M

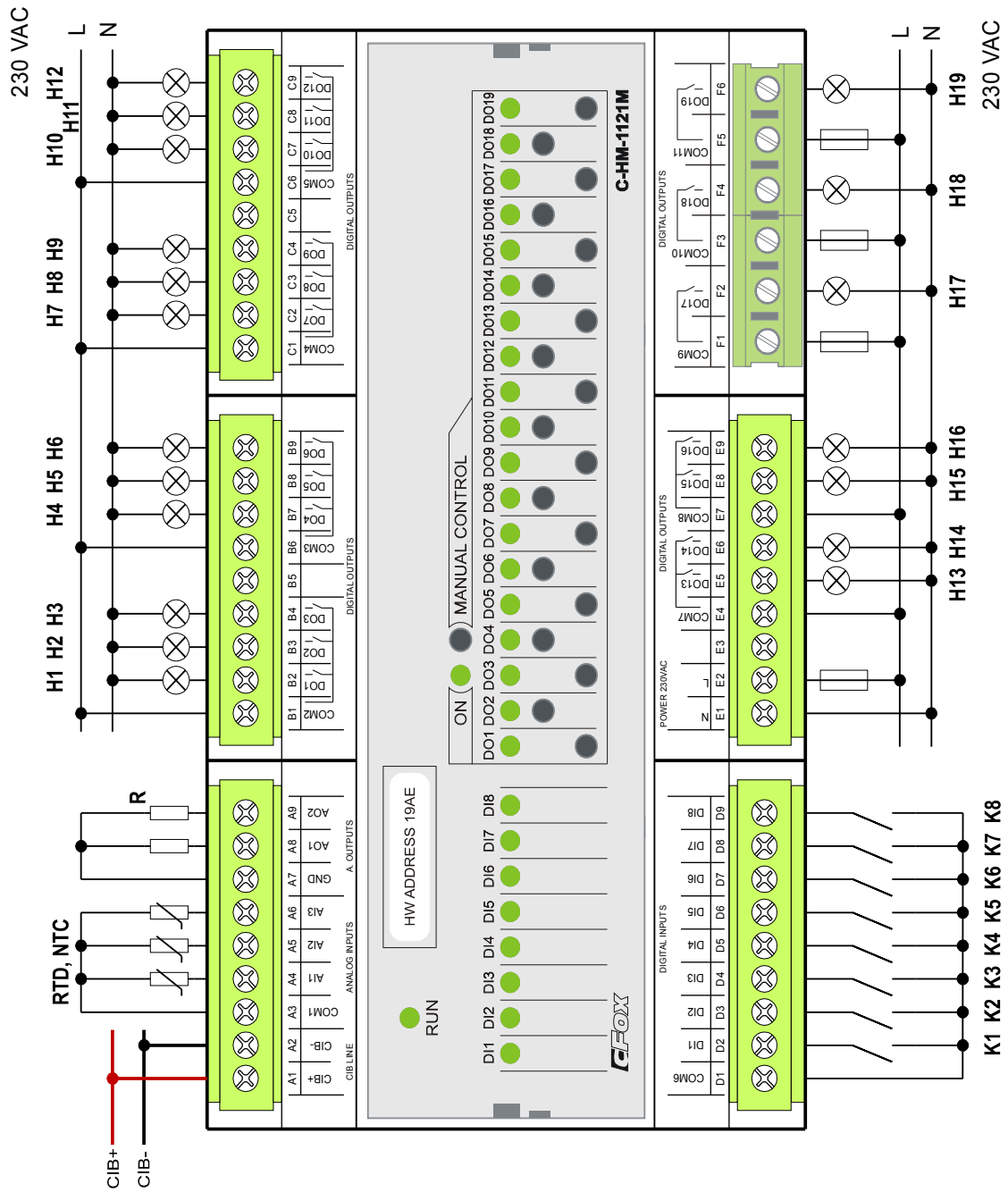

## 14.5 C-IT-0200S

Module C-IT-0200S is designed to connect two temperature sensors or dry contacts directly to the installation bus CIB. Sensors or contacts are connected by flat cable.

To measure the temperature, the resistive sensor PT1000 or Ni1000, thermistor NTC12k or KTY81-121 are to be connected between IN1 or IN2 and GND. The resistance is converted to a numerical value of temperature and transferred to the central unit over the CIB. For another type of RTD resistance measuring range can be selected from 0 to 160 k. In such case the conversion to temperature and linearisation must be done at the application program level.

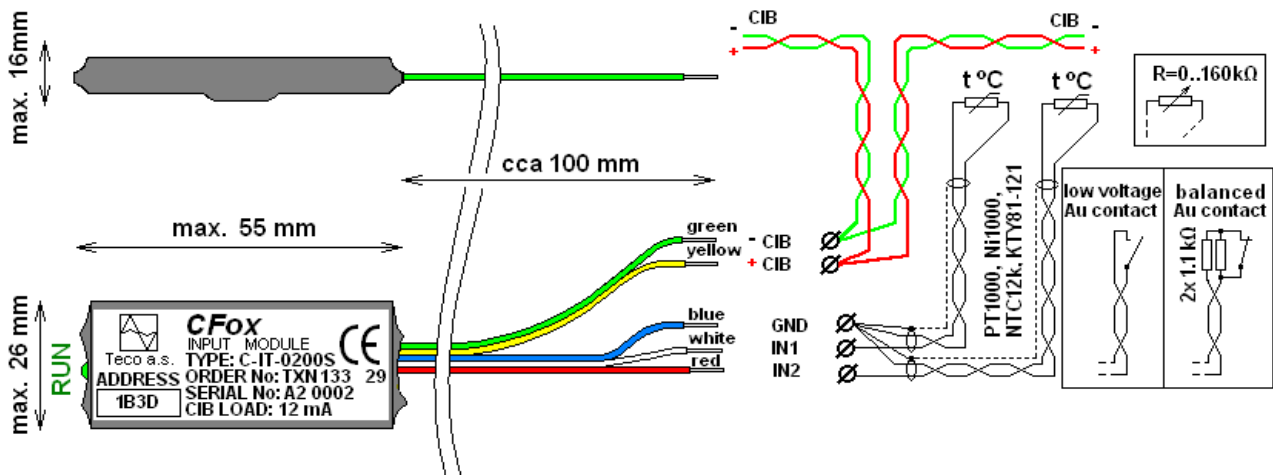



### 14.7 C-IT-0504S

Module C-IT-0504S is designed for 5 RTD sensors or dry contacts and 4 analog outputs of 0 to 10 V directly to the installation bus CIB. Inputs, outputs and the bus are to be connected via tape cable. The universal inputs can be set either to binary or analog mode in two groups during module SW configuration. The first group contains 4 inputs, the second one 1 input. Other settings are common to the whole group. For example:

- 1 temperature sensor and 4 contacts
- 1 contact and 4 temperature sensors.

To measure the temperature, the resistive sensor PT1000 or Ni1000, thermistor NTC12k or KTY81-121 are to be connected between IN1-IN5 and GND. The resistance is converted to a numerical value of temperature and transferred to the central unit over the CIB. For another type of RTD resistance measuring range can be selected from 0 to 160 k. In such case the conversion to temperature and linearisation must be done at the application program level.

The dry contacts or temperature resistors are to be connected between IN1 - IN5 and GND.

The inputs can be used as well as balanced inputs for security sensors with working contact and tamper.

Analog output is available between OUT1-OUT4 and GND.

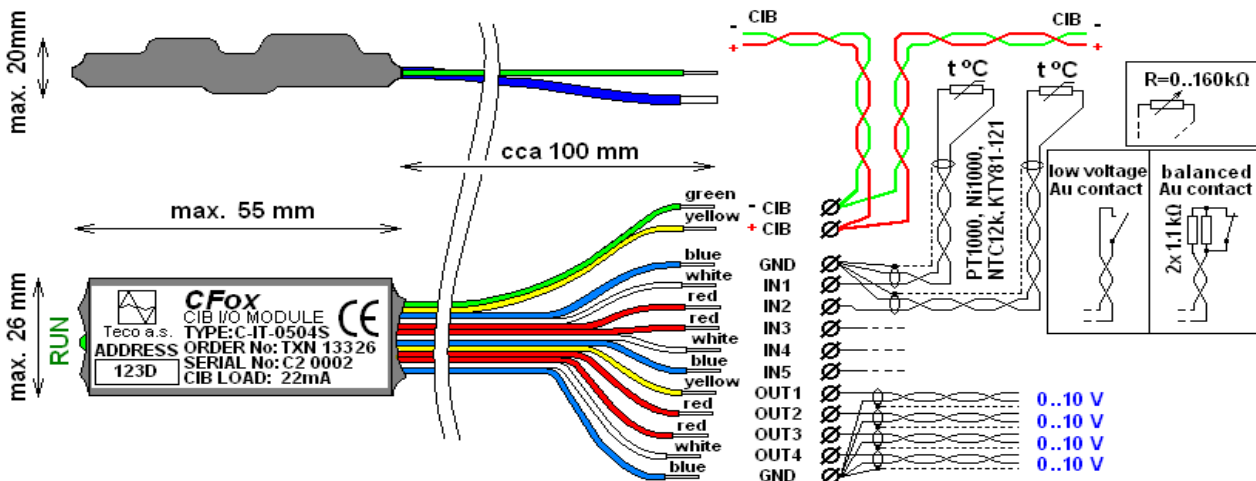

## 14.8 C-IT-0200R-Design

Module C-IT-0200R-Design works as temperature sensor assembled in various wall switch designs and can be directly connected to the installation bus CIB. The module is designed for installation into flush box on the wall.

The module C-IT-0200R-Design consists of two parts. The first – upper part includes the cover in specific design mounted on the wall.

The second – built in part is a common module for all designs of upper part. It should be placed behind the upper part into the flush box. This part is to be connected to installation bus CIB.

The module contains two RTD measurement inputs.

The first input is connected by the 2pin connector to an internal temperature sensor mounted in upper part.

The second input is ready to connect external sensor NTC 12k or to measure NTC in range up to 100k.

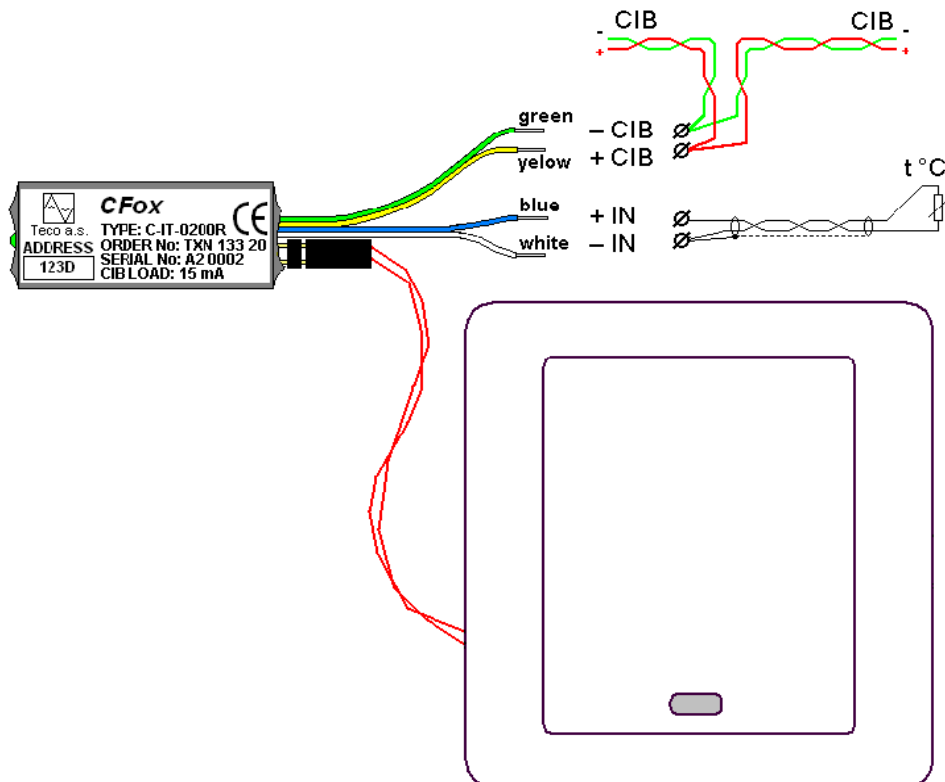



## 14.9 C-DL-0012S

Module C-DL-0012S is a converter of protocol and interface of CIB to DALI and vice versa. It is intended to control lighting equipment according to the DALI protocol specifications: NEMA Standards Publication 243-2004: Digital Addressable Lighting Interface (DALI) Control Devices Protocol PART 2-2004.

CIB and DALI bus are to be connected via flat cable. Wires has different colors. The module is powered from the CIB and does not provide galvanic isolation of the buses.

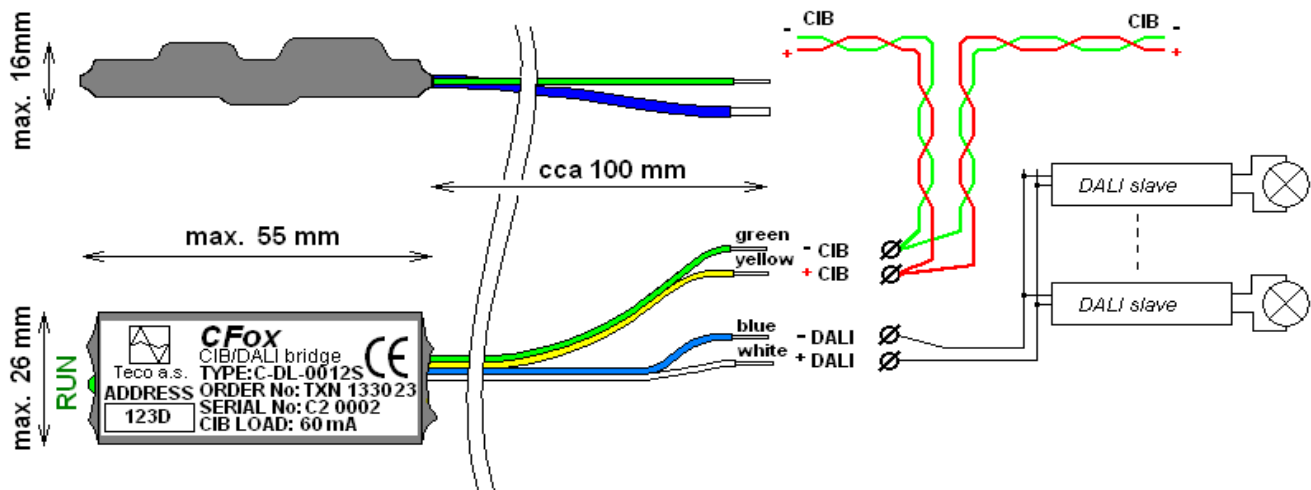

## 14.10 C-RC-0002R

Module C-RC-0002R is designed as indoor device for easy setting the room temperature. The module is available in several interior design of different manufacturers. It can be directly connected to the installation bus CIB.

The module is designed to be mounted in the flush box. The C-RC-0002R is composed of two parts. The first part is the user interface mounted on the wall and differs according to selected design of cover. The second part is a built in module to be placed in the installation flush box and allows to connect the two CIB wires. Both parts are connected by a flat cable.

The user interface includes a 3-digit 7-segment LCD display, 3 buttons and LED indicator. The module enables to measure 2 temperature sensors. The first one is a part of the cover and is permanently connected via flat cable, the second one is for external sensor and can be wired to +IN, -IN.

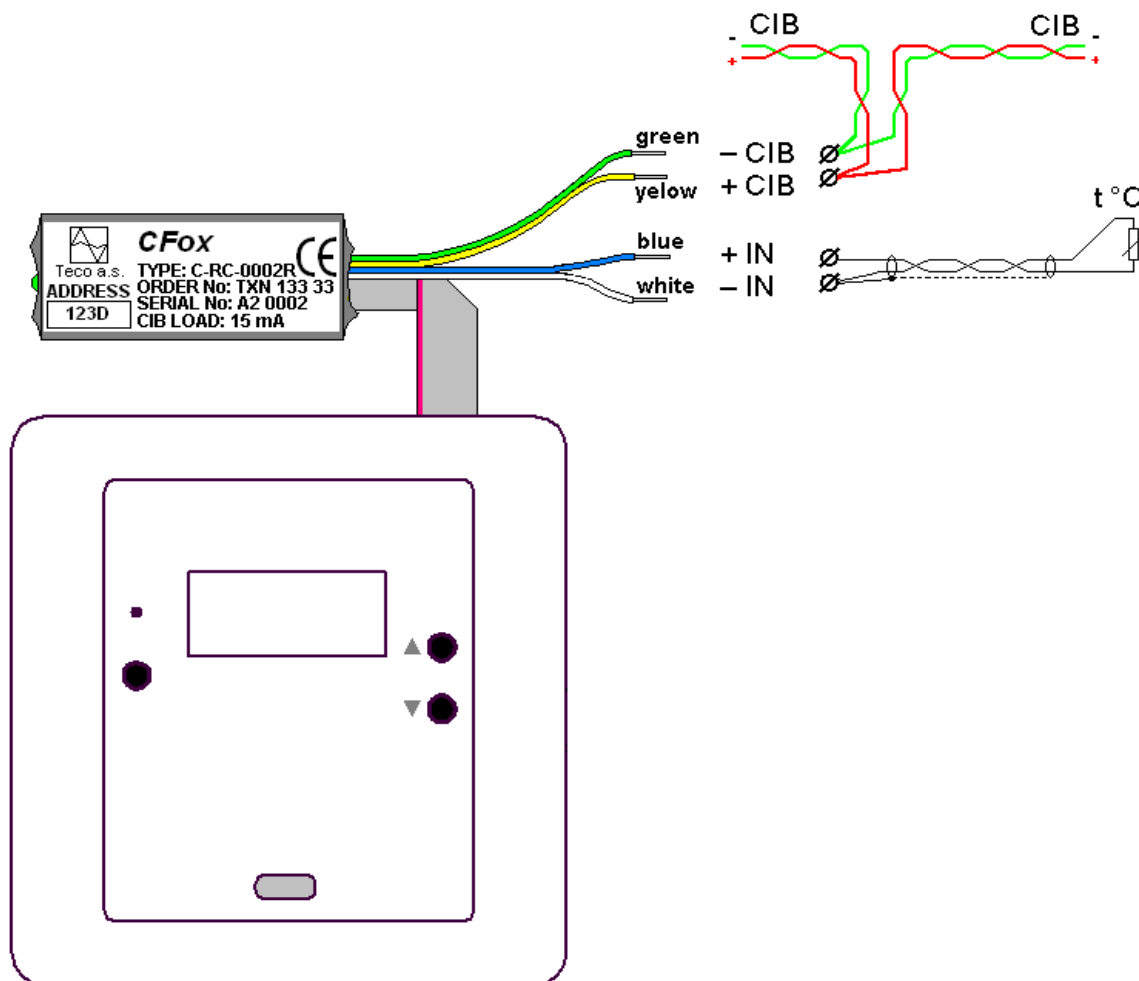

Example of already available designs (continuously extending, for others, please call us):

ABB	Tango, Alpha nea exclusive. Time , Element
Legrand	Galea, Galea Life, Valena a Cariva
Bticino	Light, Light tech, Living a Axolute
Schneider Electric	Unica Colours, Basic, Plus, Top a Quadro
EATON (Moeller/NIKO)	Original, Intense a Pure
Merten	Antique
Berker	

### 14.11 C-RI-0401R-Design, C-RI-0401R

Module C-0401R-RI-Time is a CIB flush mounted multipurpose module in the interior design. The module contains 2 universal inputs AI/DI1 and AI/DI2, which can be connected to either a resistive temperature sensor, or can be used for dry contacts. It also includes an input for light sensor as well as for receiver and transmitter of IR (infra-red) signal.

C-0401R-RI-Design is composed of two parts. The first – upper part is the user interface to be mounted on the wall and is available in different interior designs from different manufacturers. (white Time by ABB is a standard) The second part is a module to be placed in the flush box under the upper part and it allows to connect two CIB wires. Both parts are interconnected by a flat cable.

The second part is also available as C-RI-0401R standing alone module which is flexible to connect different set of used devices (IR, light sensing, AI/DI measuring - see table below), according to a specific request.

The second part with the CIB interface is also available as the standalone module C-RI-0401S for sensors and transmitter ready for customized placement and wiring.

This module must be connected to compatible light sensor, IR transmitter and receiver and LED indicating the IR operations. They are part of delivery. 2 dry contacts and external temperature sensor (Pt1000, W100 = 1385) can be connected in similar way as for another modules. The connection of wires is shown below.

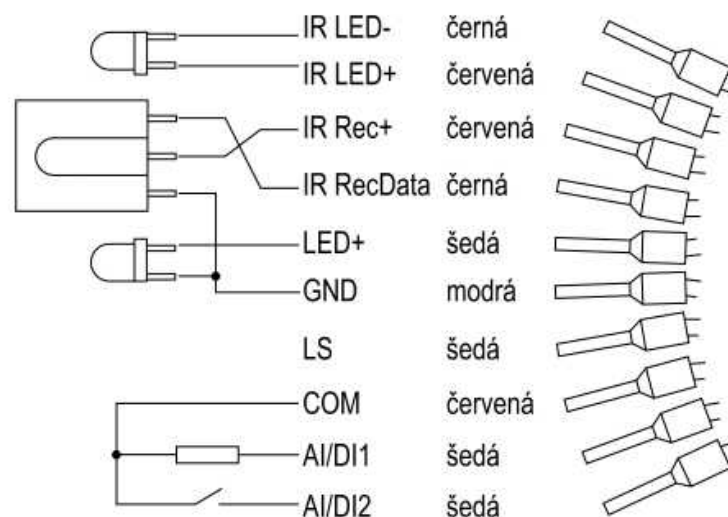

Fig. 14.11.1. Terminal wiring of C-RI-0401S (including color of wires)

Notes:

- 1) IR receiver (IR Rec), IR transmitter (IR LED) are part of delivered accessories of C-RI-0401S
- 2) LED (black, grey wires) is regular LED for IR receiving indication (Anode of LED+)
- 3) LS is light sensor input
- 4) inputs AI/DI1 and 2 are universal analog for Pt1000, Ni1000, NTC or for dry contacts
- 5) černá- black, červená-red, šedá-grey, modrá-blue,

Versions of C-RI-0401R-Time module (according the sensors assembled: IR Tx, IR Rx, light sensor, AI/DI):

Order number	Name	IR receiver, transmitter	Light sensor	AI/DI1		AI/DI2	
				Internal	External	Internal	External
				Sensor Pt1000	Terminal AI/DI	Push button	Terminal AI/DI
TXN 133 47	C-RI-0401S	embedded/flush mounting, IR Rx a Tx is part of delivery					
TXN 133 47.01	C-RI-0401R-Time	YES	YES	YES			YES
TXN 133 47.02	C-RI-0401R-Time	YES	YES	YES		YES	
TXN 133 47.03	C-RI-0401R-Time	YES	YES		YES		YES
TXN 133 47.04	C-RI-0401R-Time	YES		YES			YES
TXN 133 47.05	C-RI-0401R-Time	YES		YES		YES	
TXN 133 47.06	C-RI-0401R-Time	YES			YES		YES
TXN 133 47.07	C-RI-0401R-Time		YES	YES			YES
TXN 133 47.08	C-RI-0401R-Time		YES	YES		YES	
TXN 133 47.09	C-RI-0401R-Time		YES		YES		YES

Note:

Only TXN 133 47.01 is a standard product. The other ord. numbers has to be ordered as customized modules.

### 14.12 C-IT-0200I

C-IT-0200 is a module on the bus CIB, which includes 2 general purpose analog inputs. Inputs can be configured to measure the resistive temperature sensors, thermocouples, resistance, voltage, or current.

Module is powered from the CIB including powering of 4-20 mA current loop. The module is housed in IP-65 plastic box with bushings suitable also for outdoor installations. The external dimension of 125x100x38 mm.

Configuration of the measuring range can be done by jumpers individually for each of both inputs. Examples of using terminals and jumper configurations for various ranges are shown at figure below. Measuring ranges and input impedance of analog input module:

Input impedance	According to range:	
		RTD, NTC, OV 0÷10V, 0÷5V, -2÷2V, -1÷1V TC, HI -1÷1V, HI -100mV÷100mV Current loop 0÷20mA, 4÷20mA
Measuring range	Pt1000 - W100=1,385 Pt1000 - W100=1,391 Ni1000 - W100=1,500 Ni1000 - W100=1,617 NTC12k KTY81-121 TC - type J TC - type K TC - type R TC - type S TC - type T TC - type B TC - type N Voltage input 0÷10V Voltage input 0÷5V Voltage input -2÷2V Voltage input -1÷1V Voltage input HI -1÷1V V. in. HI -100m÷100mV Current loop 0÷20mA Current loop 4÷20mA OV 200k	
		-90°C ÷ 320°C -90°C ÷ 320°C -60°C ÷ 200°C -60°C ÷ 200°C -40°C ÷ 125°C -55°C ÷ 125°C -210°C ÷ 1200°C -200°C ÷ 1372°C -50°C ÷ 1768°C -50°C ÷ 1768°C 200°C ÷ 400°C 250°C ÷ 1820°C -200°C ÷ 1300°C 0mV ÷ 10000mV 0mV ÷ 5000mV -2000mV ÷ 2000mV -1000mV ÷ 1000mV -1000mV ÷ 1000mV -100mV ÷ 100mV 0mA ÷ 20mA 4mA ÷ 20mA 0kΩ ÷ 200kΩ

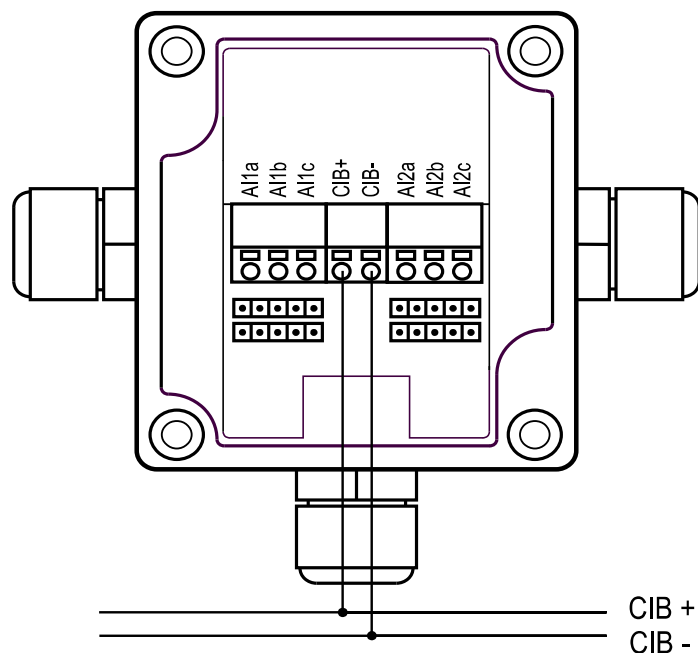
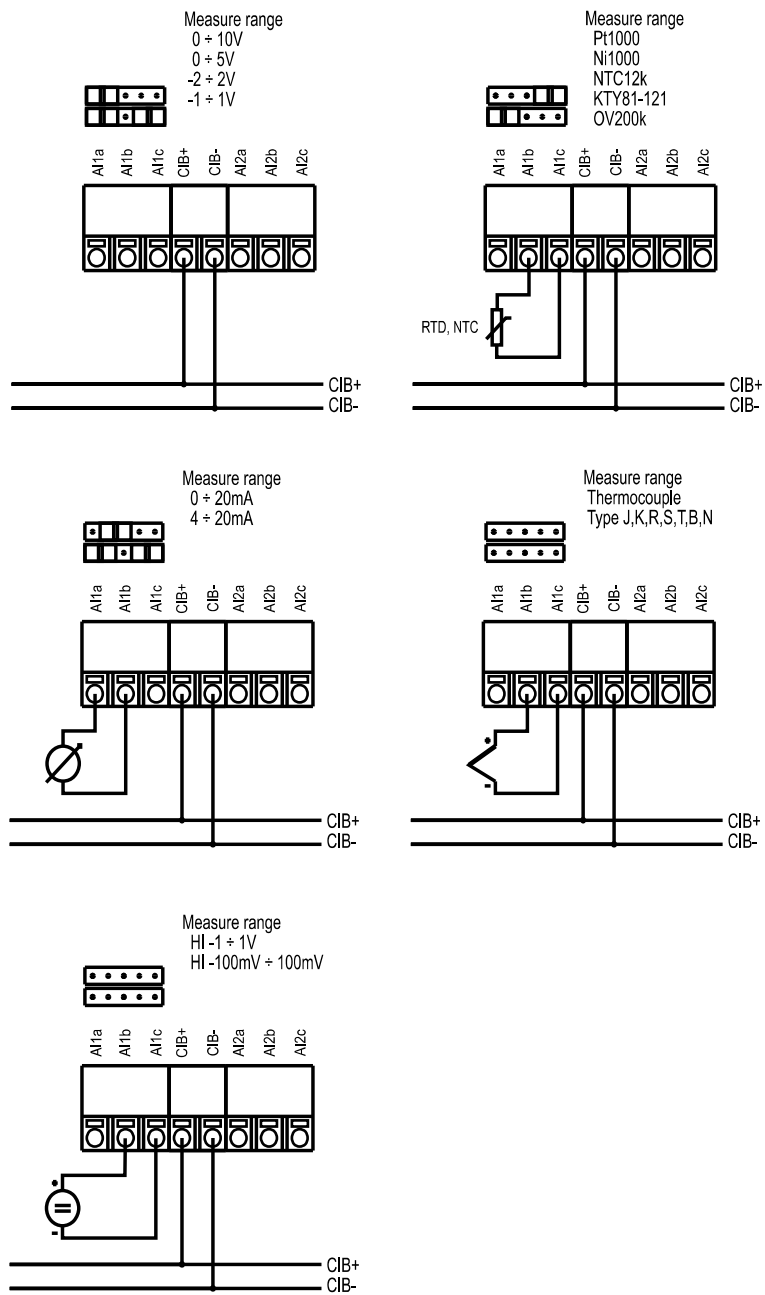

Fig. 14.12.1. CIB coupling of C-IT-0200I, position of terminals and jumpers



### 14.13 RCM2-1

RCM2-1 is the room control module on a wall intended primarily for heating or air conditioning in the interior.

The module offers a comfortable, very simple and clear control of heating in one or more rooms:

- -temperature correction,
- change of heating mode,
- manual fan speed control (stepped and smooth),
- display of outdoor temperature and time.

Additional features can be programmed on RCM2-1: heating mode indication, hot water preparation, lighting control, etc.

The module is equipped with an internal temperature sensor and it allows to connect one external sensor as well.

As option, the module can be equipped by SSR output max 60V AC / DC, 600 mA to control heating, or any other load.

The module consists of two parts. The bottom one has terminals, the hole for the cables and is to be mounted by 4 or 2 screws on the 60mm flush box.

The module is designed as a standard unit CIB bus, integrated into the environment FoxTool and Mosaic.

The module is equipped with a monochrome display with special symbols/icons. They are controlled by the Foxtrot basic module. In the Mosaic individual graphic symbols can be controlled individually as well as a numeric value on display:



## 15 Literature

- [1] Designer user manual Tecomat a Tecoreg, - ord. No. TXV 001 08
- [2] PLC Tecomat Foxtrot - manual, ord. No. TXV 004 10
- [3] Serial communication of Tecomat manual, ord. No. TXV 004 03
- [4] Foxtrot design and installation guide ord. No. TXV 004 11.
- [5]
- [6]
- [7] Jablotron documentation.